

TECHNICAL MANUAL
OPERATOR, ORGANIZATIONAL AND DIRECT
SUPPORT MAINTENANCE MANUAL INCLUDING
REPAIR PARTS AND SPECIAL TOOLS LIST
FOR
RANGE OUTFIT, FIELD, GASOLINE, MODEL M59
NSN 7360-00-082-2153

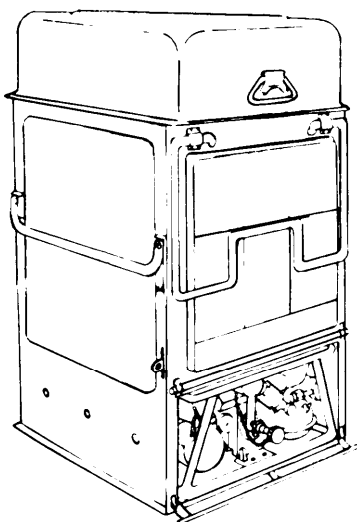

BURNER UNIT, GASOLINE, MODEL M2
 NSN 7310-00-842-9247
 BURNER UNIT, GASOLINE, MODEL M2A
 NSN 7310-01-017-1285
 BURNER UNIT, MODEL M2A
 W/SAFETY DEVICE
 NSN 7310-01-113-9172
 ACCESSORY OUTFIT, GASOLINE,
 FIELD RANGE,
 WITH BAKING RACK,
 NSN 7360-00-187-4757

	INTRODUCTION	
	OPERATING INSTRUCTIONS	
	OPERATOR MAINTENANCE INSTRUCTIONS	
	ORGANIZATIONAL MAINTENANCE INSTRUCTIONS	
	DIRECT SUPPORT MAINTENANCE INSTRUCTIONS	
APPENDIX A	REFERENCES	
APPENDIX B	MAINTENANCE ALLOCATION CHART	
APPENDIX C	COMPONENTS OF END ITEM LIST	
APPENDIX D	REPAIR PARTS AND SPECIAL TOOLS LIST	
APPENDIX E	ADDITIONAL AUTHORIZATION LIST	
APPENDIX F	EXPENDABLE SUPPLIES AND MATERIALS LIST	
	ALPHABETICAL INDEX	

This copy is a reprint which includes current pages from Changes 1 through 9.

This copy will be superseded upon receipt of DA printed manual,

HEADQUARTERS, DEPARTMENT OF THE ARMY

8 JULY 1983

CHANGE

NO. 11

HEADQUARTERS
DEPARTMENT OF THE ARMY
WASHINGTON, D.C., 21 June 1999

Operator, Organizational and Direct Support
Maintenance Manual Including
Repair Parts and Special Tools List

**RANGE OUTFIT, FIELD, GASOLINE
MODEL M59
NSN 7360-00-0822153**

**BURNER UNIT, GASOLINE,
MODEL M2
NSN 7310-00-842-9247**

**BURNER UNIT, GASOLINE,
MODEL M2A
NSN 7310-01-017-1285**

**BURNER UNIT, M2A
WITH SAFETY DEVICE
NSN 7310-01-113-9172**

**MODERN BURNER UNIT (MBU)
NSN 7310-01-452-8137**

**ACCESSORY OUTFIT, GASOLINE, FIELD RANGE,
WITH BAKING RACK
NSN 7360-00-187-4757**

DISTRIBUTION STATEMENT A: Approved for public release; distribution is unlimited

TM 10-7360-204-13&P, 8 July 1983, is changed as follows:

1. Remove and insert pages as indicated below. New or changed text material is indicated by a vertical bar in the margin. An illustration change is indicated by a miniature pointing hand.

Remove pages

i and ii

1-1 and 1-2

1-3 and 1-4

2-1 through 2-4

2-10 and 2-11

2-19 and 2-20

2-25 and 2-26

3-1 and 3-2

3-3 and 3-4

3-5 and 3-6

4-1 through 4-4

Insert pages

A and B

i and ii

1-1 and 1-2

1-3 and 1-4

2-1 through 2-4

2-10 and 2-11

2-19 and 2-20

2-25 and 2-26

3-1 and 3-2

3-3 and 3-4

3-5/(3-6 Blank)

4-1 through 4-4

C-11

Remove pages	Insert pages
4-7 through 4-10	4-7 through 4-10
4-17 and 4-18	4-17 and 4-18
---	4-18.1 and 4-18.2
---	4-18.3/(4-18.4 Blank)
4-19 and 4-20	4-19 and 4-20
5-3/(5-4 Blank)	5-3/(5-4 Blank)
C-1 through C-4	C-1 through C-4
D-7 through D-10	D-7 through D-10
D-12	(D-11 Blank)/D-12
D-13 through D-16	D-13 through D-16
D-19 and D-20	D-19 and D-20
D-23 through D-33/(D-34 Blank)	D-23 through D-33/(D-34 Blank)
E-1(E-2 Blank)	E-1(E-2 Blank)
F-1 and F-2	F-1 and F-2
Index 1 and Index 2	Index 1 and Index 2

2. Retain this sheet in front of manual for reference purposes.

By Order of the Secretary of the Army:

ERIC K. SHINSEKI
General, United States Army
Chief of Staff

Official:

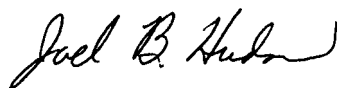

JOEL B. HUDSON
Administrative Assistant to the
Secretary of the Army
9917501

DISTRIBUTION:

To be distributed in accordance with initial distribution (IND 252578), requirements for TM 10-7360-204-13&P.

CHANGE
NO. 10

HEADQUARTERS
DEPARTMENT OF THE ARMY
WASHINGTON, D.C., 15 November 1993

Operator, Organizational and Direct Support
Maintenance Manual Including
Repair Parts and Special Tools List

RANGE OUTFIT, FIELD, GASOLINE
MODEL M59
NSN 7360-00-082-2153

BURNER UNIT, GASOLINE,
MODEL M2
NSN 7310-00-842-9247

BURNER UNIT, GASOLINE
MODEL M2A
NSN 7310-01-017-1285

BURNER UNIT, M2A
WITH SAFETY DEVICE
NSN 7310-01-113-9172

ACCESSORY OUTFIT, GASOLINE, FIELD RANGE,
WITH BAKING RACK,
NSN 7360-00-187-4757

DISTRIBUTION STATEMENT A: Approved for public release; distribution is unlimited.

TM 10-7360-204-13&P, 8 July 1983, is changed as follows:

1. Remove and insert pages as indicated below. New or changed text material is indicated by a vertical bar in the margin. An illustration change is indicated by a miniature pointing hand.

Remove pages

i and ii
1-1 and 1-2
2-3 and 2-4
2-23 and 2-24
4-15 through 4-18
4-18.1 and 4-18.2
5-1/(5-2 blank)
C-3 and C-4
D-5 through D-8
D-13 through D-16
D-25 through D-28
D-31 and D-32

Insert pages

i and ii
1-1 and 1-2
2-3 and 2-4
2-23 and 2-24
4-15 through 4-18
4-18.1 and 4-18.2
5-1/(5-2 blank)
C-3 and C-4
D-5 through D-8
D-13 through D-16
D-25 through D-28
D-31 and D-32

TM 10-7360-204-13&P

C 1 0

By Order of the Secretary of the Army:

Official:

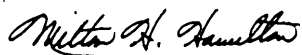

MILTON H. HAMILTON

*Administrative Assistant to the
Secretary of the Army*

05758

GORDON R. SULLIVAN
*General, United States Army
Chief of Staff*

DISTRIBUTION:

To be distributed in accordance with DA Form 12-25-E, block no. 2578, requirements for TM 10-7360-204-13&P.

CHANGE

NO. 9

HEADQUARTERS
DEPARTMENT OF THE ARMY
Washington, D. C., 31 December 1991

Operator, Organizational and Direct Support
Maintenance Manual Including
Repair Parts and Special Tools List

RANGE OUTFIT, FIELD, GASOLINE
MODEL M59
NSN 7360-00-082-2153

BURNER UNIT, GASOLINE,
MODEL M2
NSN 7310-00-842-9247

BURNER UNIT, GASOLINE,
MODEL M2A
NSN 7310-01-017-1285

BURNER UNIT, M2A WITH SAFETY DEVICE,
NSN 7310-00-113-9172

ACCESSORY OUTFIT, GASOLINE, FIELD RANGE,
WITH BAKING RACK,
NSN 7360-00-1874757

Approved for public release; distribution is unlimited

TM 10-7360-204-13&P, 8 July 1983, is changed as follows:

1, Remove and insert pages as indicated below. New or changed text material is indicated by a vertical bar in the margin. An illustration change is indicated by a miniature pointing hand.

Remove pages

a/b blank
2-23 through 2-26

Insert pages

a/b blank
2-23 through 2-26

2. Retain this sheet in front of manual for reference purposes.

TM 10-7360-204-13&P
C 9

By Order of the Secretary of the Army:

GORDON R. SULLIVAN
General, United States Army
Chief of Staff

Official:

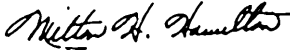

MILTON H. HAMILTON
Administrative Assistant to the
Secretary of the Army

00431

DISTRIBUTION:

To be distributed in accordance with DA Form 12-25E, (qty rqr block no. 2578)

CHANGE
NO. 8

HEADQUARTERS
DEPARTMENT OF THE ARMY
WASHINGTON, D. C., 10 June 1991

Operator, Organizational and Direct Support
Maintenance Manual including
Repair Parts and Special Tools List

**RANGE OUTFIT, FIELD, GASOLINE
MODEL M59
NSN 7360-00-082-2153**

BURNER UNIT, GASOLINE,
MODEL M2
NSN 7310-00-842-9247

BURNER UNIT, GASOLINE,
MODEL M2A
NSN 7310-01-017-1285

BURNER UNIT, M2A WITH SAFETY DEVICE,
NSN 7310-00-113-9172

ACCESSORY OUTFIT, GASOLINE, FIELD RANGE,
WITH BAKING RACK,
NSN 7360-00-187-4757

Approved for public release; distribution is unlimited

TM 10-7360-204-13&P, 8 July 1983, is changed as follows:

1. Remove and insert pages as indicated below. New or changed text material is indicated by a vertical bar in the margin. An illustration change is indicated by a miniature pointing hand.

Remove pages	Insert pages
i and ii	i and ii
1-1 through 1-6	1-1 through 1-6
2-1 through 24	2-1 through 2-4
2-13 and 2-14	2-13 and 2-14
2-17 and 2-18	2-17 and 2-18
2-21 and 2-22	2-21 and 2-22
3-3 and 3-4	3-3 and 3-4
4-9 and 4-10	4-9 and 4-10
4-15 through 4-18	4-15 through 4-18
4-18.1 and 4-18.2	4-18.1 and 4-18.2
5-1 and 5-2	5-1/(5-2 blank)
B-5 through B-7/(B-8 blank)	B-5 through B-7/(B-8 blank)
Index-1 and Index-2	Index-1 and Index-2

2. Retain this sheet in front of manual for reference purposes.

TM 10-7360-204-13&P

C8

By Order of the Secretary of the Army:

CARL E. VUONO

General, United States Army

Chief of Staff

Official:

PATRICIA P. HICKERSON

Colonel, United States Army

The Adjutant General

DISTRIBUTION:

To be distributed in accordance with DA Form 12-25E, (qty rqr block no. 2578)

CHANGE }
N O . 7 }

HEADQUARTERS
DEPARTMENT OF THE ARMY
WASHINGTON, DC, 10 october 1989

Operator, Organizational and Direct Support Maintenance Manual
Including Repair Parts and Special Tools List

RANGE OUTFIT, FIELD, GASOLINE
MODEL M59, NSN 7360-00-082-2153

BURNER UNIT, GASOLINE
MODEL M2, NSN 7310-00-842-9247

BURNER UNIT, GASOLINE
MODEL M2A, NSN 7310-01-017-1285

BURNER UNIT, M2A WITH SAFETY DEVICE
NSN 7310-01-113-9172

ACCESSORY OUTFIT, GASOLINE, FIELD RANGE,
WITH BAKING RACK
NSN 7360-00-187-4757

Approved for **public release; distribution is unlimited.**

TM 10-7360-204-13&P, 8 July 1983, is changed as follows:

1. Remove and insert pages as indicated below. New or changed text material is indicated by a vertical bar in the margin. An illustration change is indicated by a miniature pointing hand.

Remove pages

4-9 thru 4-12
C-1 and C-2
D-7 thru D-10/D-11
D-13 and D-14
D-19 and D-20/D-21
D-22
D-25 and D-26
D-29 thru D-32

Insert Pages

4-9 thru 4-12
C-1 and C-2
D-7 thru D-10/D-11
D-13 and D-14
D-19 and D-20/D-21
D-22
D-25 and D-26
D-29 thru D-32

By Order of the Secretary of the Army:

CARLE. VUONO
General, United States Army
Chief of Staff

Official:

WILLIAM J. MEEHAN, II
Brigadier General, United States Army
The Adjutant General

DISTRIBUTION:

To be distributed in accordance with DA Form 12-25A, Operator, Unit and Direct Support and General Support Maintenance Requirements for Range Outfit> Field; Gasoline, MDL M59, Burner Unit MODL M2/A; w/Safety and Accy Outfit.

CHANGE }
NO. 6 }

HEADQUARTERS
DEPARTMENT OF THE ARMY
WASHINGTON, D. , 17 MARCH 1989

Operator, Organizational and Direct Support Maintenance Manual
Including Repair Parts and Special Tools List

RANGE OUTFIT, FIELD, GASOLINE
MODEL M59, NSN 7360-00-082-2153

BURNER UNIT, GASOLINE
MODEL M2, NSN 7310-00-842-9247

BURNER UNIT, GASOLINE
MODEL M2A, NSN 7310-01-017-1285

BURNER UNIT, M2A WITH SAFETY DEVICE
NSN 7310-01-113-9172

ACCESSORY OUTFIT, GASOLINE, FIELD RANGE,
WITH BAKING RACK
NSN 7360-00-187-4757

TM 10-7360-204-13&P, 8 July 1983, is changed as follows:

1. Remove and insert pages as indicated below. New or changed text material is indicated by a vertical bar in the margin. An illustration change is indicated by a miniature pointing hand.

Remove pages

2-11 and 2-12
4-15 and 4-16
4-19 and 4-20
C-1 and C-2
F-1 and F-2

Insert pages

2-11 and 2-12
4-15 and 4-16
4-19 and 4-20
C-1 and C-2
F-1 and F-2

By Order of the Secretary of the Army:

CARLE. VUONO
General, United States Army
Chief of Staff

Official:

WILLIAM J. MEEHAN, II
Brigadier General, United States Army
The Adjutant General

DISTRIBUTION:

To be distributed in accordance with DA Form 12-25A, Operator, Unit and Direct Support and General Support Maintenance Requirements for Range Outfit, Field; Gasoline, MDL M59, Burner Unit MODL M2/A; w/Safety and Accy Outfit.

CHANGE }
NO. 5 }

HEADQUARTERS
DEPARTMENT OF THE ARMY
WASHINGTON, D. C. , 22 June 1988

Operator, Organizational and Direct Support Maintenance Manual

RANGE OUTFIT, FIELD, GASOLINE
MODEL M59 NSN 7360-00-082-2153

BURNER UNIT, GASOLINE
MODEL M2A, NSN 7310-00-842 9247

BURNER UNIT, GASOLINE
MODEL M2A, NSN 7310-01-017-1285

BURNER UNIT, M2A WITH SAFETY DEVICE
NSN 7310-01-113-9172

ACCESSORY OUTFIT, GASOLINE, FIELD RANGE,
WITH BAKING RACK
NSN 7360-00-187-4757

TM 10-7360-204-13&P, 8 July 1983, is changed as follows:

1. Remove and insert pages as indicated below. New or changed text material is indicated by a vertical bar in the margin. An illustration change is indicated by a miniature pointing hand.

Remove pages

2-7 and 2-8
2-13 and 2-14
4-19 and 4-20
B-5 and B-6
D-7 and D-8
D-19 and D-20
D-23 through D-26
D-29 through D-32

Insert pages

2-7 and 2-8
2-13 and 2-14
4-19 and 4-20
B-5 and B-6
D-7 and D-8
D-19 and D-20
D-23 through D-26
D-29 through D-32

2. Retain this sheet in front of manual for reference purposes.

By Order of the Secretary of the Army:

CARLE. VUONO
General, United States Army
Chief of Staff

Official:

R. L. DILWORTH
Brigadier General, United States Army
The Adjutant General

DISTRIBUTION:

To be distributed in accordance with DA Form 12-25A, Operator, Unit, Direct Support and General Support Maintenance requirements for Range Outfit, Field; Gasoline, MDL M59; Burner Unit MDL M2/A; w/Safety Device & Outfit.

CHANGE }
No. 4 }

HEADQUARTERS
DEPARTMENT OF THE ARMY
WASHINGTON, D. C. , 20 January 1988

Operator, Organizational and Direct Support Maintenance Manual

RANGE OUTFIT, FIELD, GASOLINE
MODEL M59, NSN 7360-00-082-2153

BURNER UNIT, GASOLINE
MODEL M2, NSN 7310-00-842-9247

BURNER UNIT, GASOLINE
MODEL M2A, NSN 7310-01-017-1285

BURNER UNIT, M2A WITH SAFETY DEVICE
NSN 7310-01-113-9172

ACCESSORY OUTFIT, GASOLINE, FIELD RANGE,
WITH BAKING RACK
NSN 7360-00-187-4757

TM 10-7360-204-13&P, 8 July 1983, is changed as follows:

1. Remove and insert pages as indicated below. New or changed text material is indicated by a vertical bar in the margin. An illustration change is indicated by a miniature pointing hand.

Remove pages

a/b
2-7 and 2-8
2-13 through 2-18
3-1 and 3-2
4-3 and 4-4
4-15 and 4-16
4-19 and 4-20
B-1 through B-5/B-6
C-1 and C-2
D-7 through D-20
D-23 through D-26
D-29 through D-32

Insert pages

a/b
2-7 and 2-8
2-13 through 2-18
3-1 and 3-2
4-3 and 4-4
4-15 and 4-16
4-19 and 4-20
B-1 through B-7/B-8
C-1 and C-2
D-7 through D-20
D-23 through D-26
D-29 through D-32

2. Retain this sheet in front of manual for reference purposes.

By Order of the Secretary of the Army:

CARL E. VUONO
General, United States Army
Chief of Staff

Official:

R. L. DILWORTH
Brigadier General, United States Army
The Adjutant General

DISTRIBUTION:

To be distributed in accordance with DA Form 12-25A, Operator, Unit, and Direct Support and General Support Maintenance requirements for Range Outfit, Field; Gasoline, MDL M59; Burner Unit MDL M2/A; w/Safety Device & Accy Outfit.

CHANGE }
 No. 3 }

HEADQUARTERS
 DEPARTMENT OF THE ARMY
 WASHINGTON, D. C., 30 January 1987

Operator, Organizational and Direct Support Maintenance Manual
 Including Repair Parts and Special Tools List

RANGE OUTFIT, FIELD, GASOLINE
 MODEL M59, NSN 7360-00-082-2153

BURNER UNIT, GASOLINE
 MODEL M2, NSN 7310-00-842-9247

BURNER UNIT, GASOLINE
 MODEL M2A, NSN 7310-01-017-1285

BURNER UNIT, M2A WITH SAFETY DEVICE
 NSN 7310-01-113-9172

ACCESSORY OUTFIT, GASOLINE, FIELD RANGE,
 WITH BAKING RACK
 NSN 7360-00-187-4757

TM 10-7360-204-13&P, 8 July 1983, is changed as follows:

1. Remove and insert pages as indicated below. New or changed text material is indicated by a vertical bar in the margin. An illustration change is indicated by a miniature pointing hand.

Remove pages

D-7 and D-8
 D-29 through D-32

Insert pages

D-7 and D-8
 D-29 through D-32

2. Retain this sheet in front of manual for reference purposes.

By Order of the Secretary of the Army:

JOHN A. WICKHAM, JR.
General, United States Army
Chief of Staff

Official:

R. L. DILWORTH
Brigadier General, United States Army
The Adjutant General

DISTRIBUTION:

To be distributed in accordance with DA Form 12-25A, Operator, Unit, and Direct Support and General Support Maintenance Requirements for Range Outfit, Field; Gasoline, MDL M59; Burner Unit MDL M2/A; w/Safety and Accy Outfit.

CHANGE }
NO. 2 }

HEADQUARTERS
DEPARTMENT OF THE ARMY
WASHINGTON, D. C., 29 August 1986

Operator, Organizational and Direct Support
Maintenance Manual including
Repair Parts and Special **Tools List**

**RANGE OUTFIT, FIELD, GASOLINE
MODEL M59
NSN 7360-00-082-2153**

**BURNER UNIT, GASOLINE,
MODEL M2
NSN 7310-00-842-9247**

**BURNER UNIT, GASOLINE
MODEL M2A
NSN 7310-01-017-1285**

**BURNER UNIT, M2A
WITH SAFETY DEVICE
NSN 7310-01-113-9172**

**ACCESSORY OUTFIT, GASOLINE, FIELD RANGE,
WITH BAKING RACK,
NSN 7360-00-187-4757**

TM 10-7360-204-13&P, 8 July, 1983, is changed as follows:

1. Remove and insert pages as indicated below. New or changed text material is indicated by a vertical bar in the margin. An illustration change is indicated by a miniature pointing hand.

Remove pages

a/b
1-3 and 1-4
2-7 and 2-8
2-13 through 2-18
4-3 and 4-4
4-11 and 4-12
4-17 and 4-18
4-18.1 and 4-18.2
4-19 and 4-20
B-3 and B-4
C-3 and C-4
D-7 through D-10
D-13 through D-16
D-19 and D-20
D-23 through D-28

F-1 and F-2

Insert pages

a/b
1-3 and 1-4
2-7 and 2-8
2-13 through 2-18
4-3 and 4-4
4-11 and 4-12
4-17 and 4-18
4-18.1 and 4-18.2
4-19 and 4-20
B-3 and B-4
C-3 and C-4
D-7 through D-10
D-13 through D-16
D-19 and D-20
D-23 through D-28
D-33/D-34
F-1 and F-2

2. Retain this sheet in front of manual for reference purposes.

By Order of the Secretary of the Army:

Official:

R. L. DILWORTH
Brigadier General, United States Army
The Adjutant General

JOHN A. WICKHAM, JR.
General, United States Army
Chief of Staff

DISTRIBUTION:

To be distributed in accordance with DA Form 12-25A, Operator, Organizational, Direct Support and General Support Maintenance Requirements for Kitchen, Field, Mobile, Trailer Mounted (MKT-75) (TM 10-7360-206 Series)

CHANGE }
NO. 1 }

HEADQUARTERS
DEPARTMENT OF THE ARMY
WASHINGTON, D. C., 12 December 1985

OPERATOR, ORGANIZATIONAL AND DIRECT SUPPORT
MAINTENANCE MANUAL INCLUDING
REPAIR PARTS AND SPECIAL TOOLS LIST

RANGE OUTFIT, FIELD, GASOLINE
MODEL M59
NSN 7360-00-082-2153

BURNER UNIT, GASOLINE,
MODEL M2
NSN 7310-00-842-9247

BURNER UNIT, GASOLINE
MODEL M2A
NSN 7310-01-017-1285

BURNER UNIT, M2A
WITH SAFETY DEVICE
NSN 7310-01-113-9172

ACCESSORY OUTFIT, GASOLINE, FIELD RANGE,
WITH BAKING RACK,
NSN 7360-00-187-4757

TM 10-7360-204-13&P, 8 July, 1983, is changed as follows:

1. Remove and insert pages as indicated below. New or changed text material is indicated by a vertical bar in the margin. An illustration change is indicated by a miniature pointing hand.

Remove pages

i through iii/iv
1-1 through 1-6
2-7 and 2-8
2-17 and 2-18
2-23 through 2-26
4-7 through 4-12
4-15 through 4-18
4-19 and 4-20
5-1 and 5-2
B-1 and B-2
C-1 through C-4
D-3 and D-4
D-7 and D-8
D-13 through D-20
D-23 through D-30
E-1/E-2
F-1 and F-2
Index 3/Index 4

Insert pages.

i through iii/iv
1-1 through 1-6
2-7 and 2-8
2-17 and 2-18
2-23 through 2-26
4-7 through 4-12
4-15 through 4-18.2
4-19 and 4-20
5-1 and 5-2
B-1 through B-2.1/B-2.2
C-1 through C-4
D-3 and D-4
D-7 and D-8
D-13 through D-20
D-23 through D-30
E-1/E-2
F-1 and F-2
Index 3/Index 4

2. Retain this sheet in front of manual for reference purposes.

By Order of the Secretary of the Army:

JOHN A. WICKHAM, JR.
General, United States Army
Chief of Staff

Official:

MILDRED E. HEDBERG
Brigadier General, United States Army
The Adjutant General

DISTRIBUTION:

To be distributed in accordance with DA Form 12-25A, Operator, Organizational, Direct Support and General Support Maintenance Requirements for Kitchen, Field, Mobile, Trailer Mounted (MKT-75) (TM 10-7360-206 Series)

WARNING

Flammable liquids are used in the operation
of this equipment

DEATH

or severe burns may result if personnel
fail to observe safety precautions

- Provide adequate ventilation to prevent the accumulation of carbon monoxide, which is a colorless, poisonous gas. If present, VENTILATE IMMEDIATELY. If symptoms persist, move personnel to fresh air keep warm; DO NOT PERMIT PHYSICAL EXERCISE; if necessary, give artificial respiration. FOR ARTIFICIAL RESPIRATION, REFER TO FM 21-11. Make sure the burner is turned off, and allow the unit to cool before filling the fuel tank. Do not smoke, and make sure there is no open flame in the vicinity. When filling the fuel tank, always provide a metal-to-metal contact between the container and the fuel tank. **Remove** spilled fuel immediately. Keep fuel tank and fuel container caps tight at all times. Do not store fuel containers near heat or open flame. Never operate range burner without top shield installed. Make sure that the sliding doors in the middle of cabinet are fully open when burner is installed and operating in the middle position. Make sure there is no fuel or other inflammable material on or near the burner unit. **Do** not release the fuel air pressure until the burner has been turned off and allowed to cool. Gasoline fumes are explosive and highly flammable.
- If a fuel leak is detected, shut the unit down immediately. **Do** not operate again until the deficiency has been corrected. Do not fill the fuel tank while the unit is operating. Do not operate burner unit when pressure gage reads in the red. For overnight or short periods of storage with fuel remaining in the tank, release air pressure, hand" tighten fuel filler cap, stow burner unit on back end in vertical position.
- An air compressor will be used to pressurize the fuel tank when testing the safety valve device at organizational level maintenance. At all other times the hand air pump will be used to pressurize the fuel tank.
- If during operation, the flame goes out for any reason, immediately close generator valve to prevent accumulation of fuel and possible explosion.
- Move the burner units a minimum of 50 feet from the cooking and fuel storage areas prior to servicing.
- Establish a safe lighting area that is a minimum of 50 feet from the refueling and cooking area.
- Dry cleaning solvent, P-D-680, used to clean parts is potentially dangerous to personnel and property. Avoid repeated and prolonged skin contact. Do not use near open flame or excessive heat. Flash point of solvent is 100 degrees F to 138 degrees F (38 degrees C to 59 degrees C).
- Do not change setting on safety valve device.
- Never put more than one burner unit in the field range cabinet. Before placing a burner unit in either cabinet position, check to be sure the other position is empty. operating a range with two burner units could lead to injury or death.

INSERT LATEST CHANGED PAGES/WORK PACKAGES, DESTROY SUPERSEDED DATA.

LIST OF EFFECTIVE PAGES/WORK PACKAGES

NOTE: The portion of text affected by the changes is indicated by a vertical line in the outer margins of the page. Changes to illustrations are indicated by miniature pointing hands or vertical lines adjacent to the title.

Dates of issue for original and changed pages/work packages are:

Original0...8 July 1983	Change ...6...17 March 1989
Change ...1...12 December 1985	Change ...7...10 October 1989
Change ...2...29 August 1986	Change...8...10 June 1991
Change ...3...30 January 1987	Change ...9...31 December 1991
Change ...4...20 January 1988	Change ...10...15 November 1993
Change ...5...22 June 1988	Change ...11...21 June 1999

TOTAL NUMBER OF PAGES 128 AND TOTAL NUMBER OF WORK PACKAGES IS 0, CONSISTING OF THE FOLLOWING:

Page/WP No.	*Change No.	Page/WP No.	*Change No.
Title	0	2-18	8
Warning a/b	9	2-19	11
i and ii	11	2-20	0
u iii	1	2-21	8
1-1	11	2-22	0
1-2	8	2-23 and 2-24	10
1-3	11	2-25	11
1-4 and 1-5	8	2-26	0
1-6 and 1-7/(8blank)	0	3-1	11
2-1	11	3-2	4
2-2	8	3-3	11
2-3 and 2-4	11	3-4	0
2-5 and 2-6	0	3-5/(3-6 blank)	11
2-7	5	4-1	0
2-8	4	4-2 thru 4-4	11
2-9	0	4-5 and 4-6	0
2-10 and 2-11	11	4-7	1
2-12	0	4-8 and 4-9	11
2-13	8	4-10 thru 4-12	7
2-14	5	4-13 thru 4-15	0
2-15	4	4-16	10
2-16	0	4-17 and 4-18	11
2-17	1	4-18.1/(4-18.2 blank)	11

* Zero in this column indicates an original page or work package

Page/WP No.	*Change No.	Page/WP No.	*Change No.
4-18.3/(4-18.4 blank)	11		
4-19	6		
4-20	11		
5-1/(5-2 blank)	10		
5-3/(5-4 blank)	11		
A-1/(A-2 blank)	11		
B-1 and B-2	4		
B-2.1/(B-2.2 blank)	1		
B-3	4		
B-4	0		
B-5 thru B-7/(B-8 blank)	8		
C-1	1		
C-2 thru C-4	11		
D-1 thru D-3	0		
D-4	1		
D-5	10		
D-6 and D-7	0		
D-8	10		
D-9	7		
D-10/(D-11 blank)	4		
(D-11.1 blank)/D-12	11		
D-13 thru D-15	11		
D-16	0		
D-17	4		
D-18	0		
D-19	11		
D-20/(D-21 blank)	7		
D-22	0		
D-23	4		
D-24	5		
D-25	11		
D-26 and D-27	10		
D-28	0		
D-29	3		
D-30	7		
D-31 and D-32	10		
D-33/(D-34 blank)	2		
E-1/(E-2 blank)	1		
F-1 and F-2	11		
INDEX 1	11		
INDEX 2	0		
INDEX 3/INDEX 4 blank	1		

* Zero in this column indicates an original page or wok package

TECHNICAL MANUAL

No. 10-7360-204-13&P

HEADQUARTERS
DEPARTMENT OF THE ARMY
WASHINGTON, D.C., 8 July 1983

**OPERATOR, ORGANIZATIONAL AND DIRECT SUPPORT
MAINTENANCE MANUAL INCLUDING
REPAIR PARTS AND SPECIAL TOOLS LIST**

**RANGE OUTFIT, FIELD, GASOLINE
MODEL M59
NSN 7360-00-082-2153**

**BURNER UNIT, GASOLINE,
MODEL M2
NSN 7310-00-842-9247**

**BURNER UNIT, GASOLINE
MODEL M2A
NSN 7310-01-017-1285**

**BURNER UNIT, M2A
WITH SAFETY DEVICE
NSN 7310-01-113-9172**

**ACCESSORY OUTFIT, GASOLINE, FIELD RANGE,
WITH BAKING RACK,
NSN 7360-00-187-4757**

REPORTING ERRORS AND RECOMMENDING IMPROVEMENTS

You can help improve this manual. If you find any mistakes or if you know of a way to improve the procedures, please let us know. Mail your letter or DA Form 2028 (Recommended Changes to Publications and Blank Forms), or DA Form 2028-2 located in the back of this manual directly to: Commander, U.S. Army Soldier and Biological Chemical Command, ATTN: AMSSB-RIM-L(N), Kansas Street, Natick, MA 01760-5052. You may also send in your recommended changes via electronic mail directly to amssb-rim-e@natick-amed02.army.mil. A reply will be furnished directly to you. Instructions for sending an electronic 2028 may be found at the back of this manual immediately preceding the hard copy 2028.

DISTRIBUTION STATEMENT A: Approved for public release; distribution is unlimited.

TABLE OF CONTENTS

		PAGE
CHAPTER	1.	INTRODUCTION
Section	I.	GENERAL INSTRUCTION 1-1
Section	II.	EQUIPMENT DESCRIPTION..... 1-1
Section	III.	TECHNICAL PRINCIPLES OF OPERATION 1-7
CHAPTER	2.	OPERATING INSTRUCTIONS
Section	I.	DESCRIPTION AND USE OF OPERATOR'S CONTROLS AND INDICATORS..... 2-1
Section	II.	OPERATION UNDER USUAL CONDITIONS 2-11
Section	III.	OPERATION UNDER UNUSUAL CONDITIONS..... 2-25

* This manual supersedes TM 10-7360-204-13&P, 11 September 1981.

TABLE OF CONTENTS

CHAPTER	3.	<u>OPERATOR MAINTENANCE INSTRUCTIONS</u>	
Section	I.	LUBRICATION INSTRUCTIONS.....	3-1
Section	II.	TROUBLESHOOTING	3-1
Section	III.	MAINTENANCE PROCEDURES	3-3
CHAPTER	4.	<u>ORGANIZATIONAL MAINTENANCE INSTRUCTIONS</u>	
Section	I.	GENERAL	4-1
Section	II.	REPAIR PARTS, SPECIAL TOOLS, AND SUPPORT EQUIPMENT	4-1
Section	III.	SERVICE UPON RECEIPT	4-1
Section	IV.	PREVENTIVE MAINTENANCE CHECKS AND SERVICES	4-1
Section	V.	TROUBLESHOOTING	4-3
Section	VI.	MAINTENANCE PROCEDURES	4-5
Section	VII.	SERVICE BEFORE STORAGE.....	4-19
Section	VIII.	STORAGE AFTER PREPARATION FOR STORAGE	4-20
CHAPTER	5.	DIRECT SUPPORT MAINTENANCE INSTRUCTIONS	
Section	I.	GENERAL.....	5-1
Section	II.	CABINET	5-1
Section	III.	DELETED	
APPENDIX	A.	<u>REFERENCES</u>	A-1
APPENDIX	B.	<u>MAINTENANCE ALLOCATION CHART</u>	B-1
■ APPENDIX	C.	<u>COMPONENTS OF END ITEM LIST</u>	C-1
APPENDIX	D.	<u>REPAIR PARTS AND SPECIAL TOOLS LIST</u>	D-1
APPENDIX	E.	<u>ADDITIONAL AUTHORIZATION LIST</u>	E-1
■ APPENDIX	F.	<u>EXPENDABLE SUPPLIES AND MATERIALS LIST</u>	F-1
INDEX			I-1

LIST OF ILLUSTRATIONS

Figure Page	Title	
Figure 1-1.	Field Range Outfit	1-2
■ Figure 1-2.	Location and Description of Range Outfit Major Components (Sheet 1 of 2).....	1-4
Figure 1-3.	Location and Description of Burner Unit Major Components (Sheet 2 of 2).....	1-6
Figure 2-1.	Operating Controls Field Range Outfit.....	2-2
Figure 2-2.	Operating Controls Burner.....	2-3
Figure 2-3.	Field Range Accessories Outfit	2-4
Figure 2-4.	Multiple Units	2-13
Figure 2-5.	Burner Removal.....	2-13
Figure 2-6.	Burner Cleaning	2-14
Figure 2-7.	Closing Valves.....	2-14
Figure 2-8.	Servicing Fuel Tank (Sheet 1 of 2).....	2-15
Figure 2-8.	Servicing Fuel Tank (Sheet 2 of 2).....	2-16
Figure 2-9.	Baking Rack Set, Removal and Replacement	2-17
Figure 3-1.	Generator Removal	3-4
Figure 3-2.	Packing the Generator FlameValve	3-5
Figure 3-3.	Air Valve Assembly Repair (deleted per change 11)	3-6
Figure 4-1.	Preheater Assembly, Exploded View.....	4-13
Figure 4-2.	Packing the Preheater Valve	4-14
Figure 4-3.	Safety Device Assembly	4-18.2
Figure 4-4.	Safety System Template	4-18.3

Table of Contents - Continued

LIST OF ILLUSTRATIONS - Continued

Figure	Title	Page
D-1	Cabinet Assembly	D-5
D-2	Field Range Outfit	D-12
D-3	Accessory Outfit	D-14
D-4	Burner Unit	D-16
D-5	Preheater Assembly	D-22
D-6	Fuel Tank Assembly	D-24
D-7	Safety Valve Device	D-26
D-8	Special Wrench	D-28

LIST OF TABLES

Table	Title	Page
2-1	Preventive Maintenance Checks and Services-Operator	2-5
3-1	Operator Troubleshooting	3-1
4-1	Preventive Maintenance Checks and Services -Organizational	4-2
4-2	Troubleshooting	4-4
F-1	Expendable Supplies and Materials List	F-2

CHAPTER 1 INTRODUCTION

Section I. GENERAL INSTRUCTIONS

1-1. SCOPE.

Type of Manual: Operator Organizational and Direct Support Maintenance Manual including Repair Parts and Special Tools List.

Model Number and Equipment Name:
MSQ - Field Range Outfit and Associated Accessory Outfits.

Purpose of Equipment: The range (Figure 1-1) is used to cook food in the field.

1-2. MAINTENANCE FORMS, RECORDS, AND REPORTS.

Department of the Army forms and procedures used for equipment maintenance will be those prescribed by DA PAM 738-750. The Army Maintenance Management System (TAMMS).

1-3. REPORTING EQUIPMENT IMPROVEMENT RECOMMENDATIONS (EIR).

If your field range outfit needs improvement let us know. Send us an EIR. You, the user, are the only one who can tell us what you don't like about your equipment. Let us know why you don't like the design. Tell us why a procedure is hard to perform. Put it on an SF 368 (Quality Deficiency Report). Mail it to us at: Commander, U.S. Army Soldier Biological and Chemical Command, ATTN: AMSSB-RIM-L(N), Kansas Street, Natick, MA 01760-5052. We'll send you a reply.

Section II. EQUIPMENT DESCRIPTION

1-4 .EQUIPMENT PURPOSE, CAPABILITIES AND FEATURES.

- a. *Purposes of Field Range Outfit.* A portable range used to cook food in the field.
- b. *Capabilities and Features.*

PORTABLE - Used in the field or in an indoor area with proper ventilation.

SELF- CONTAINED - Has a fuel supply tank and heat producing burner.

USED FOR - Cooking or baking.

COMPLETE - Contains all pots, pans, knives, forks and spoons, needed for cooking and a cabinet in which to cook.

The field range outfit consists of a range cabinet and burner unit, plug pots, pans, and other cooking utensils, and equipment for preparing food in the field or in an indoor area with proper ventilation.

The burner unit is:

SELF- CONTAINED - Has its own fuel tank for gasoline, a fire-heat assembly, and heat generator.

PORTABLE - Can be used with cabinet or by itself.

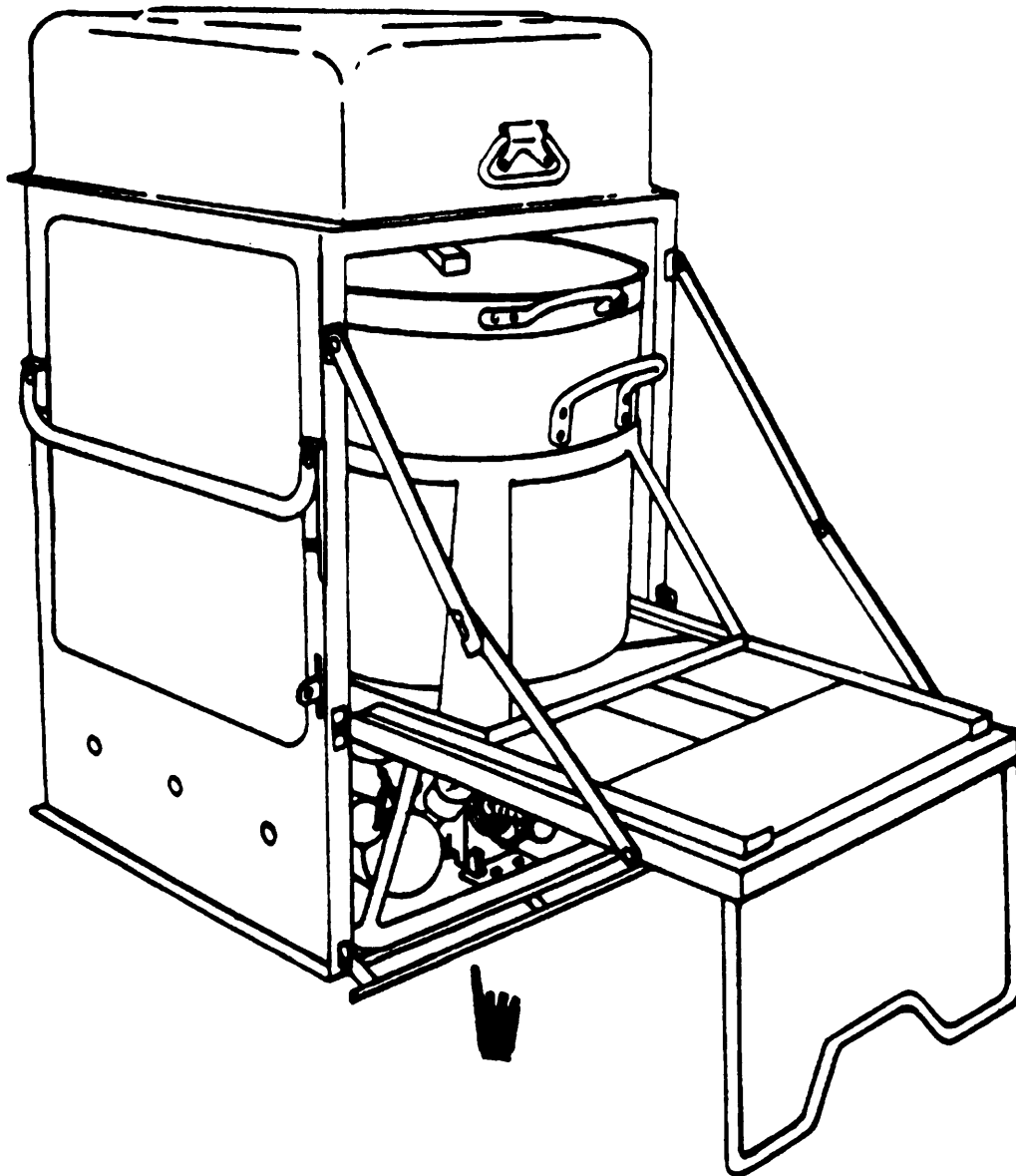

Figure I-1. Field Range Outfit

THE ACCESSORY OUTFIT consists of a tool chest with cleaning tools, brushes, scrapers and cleaners.

FOOD TOOLS- Can openers, egg whips, baking racks.

MAINTENANCE TOOLS - Wrenches, screw drivers.

OPERATING TOOL - Air pump.

SAFETY - Fire extinguisher.

1-5. LOCATION AND DESCRIPTION OF MAJOR COMPONENTS.

1-5.1 Field Range Outfit major components are shown and described in figure 1-2.

1-5.2 Burner Unit major components are shown and described in figure 1-3.

1-5.3 Field Range accessories outfit is shown in figure 2-3.

1-5.4 For information on the Modern Burner Unit (MBU), refer to TM 10-7360-281-13&P.

1-6. DIFFERENCES BETWEEN MODELS.

This manual covers Range Outfit, Model M59, Burner Model M2A with safety device, and M2A, and Accessory Outfits which are built to Military Specifications from Military Drawings. All components and parts are interchangeable no matter where they were made.

The differences between the three Model Burner Units are as follows:

- a. Model M2A with Safety Device has a Safety Device Assembly installed during production.
- b. Models M2A and M2A with Safety Device have slightly different design in U Tank and Mixing Chamber than the Model M2.

1-7. EQUIPMENT DATA

a. RANGE OUTFIT

Manufacture	Many
Model	M59
Stock Number	NSN 7360-00-082-2153

b. BURNER UNIT, GASOLINE

Manufacture	Many
Model	M2
Stock Number	NSN 7310-00-842-9247

c. BURNER UNIT, GASOLINE

Manufacture	Many
Model	M2A
Stock Number	NSN 7310-00-017-1285

d. BURNER UNIT, GASOLINE

Manufacture	Many
Model	M2A with Safety Device
Stock Number	NSN 7310-00-842-9247

e. BURNER UNIT, MODERN*

Manufacture	Teleflex (Canada)
Model	Modern Burner Unit
Stock Number	NSN 7310-01-452-8137

*for more information on the Modern Burner Unit (MBU) refer to TM 10-7360-281-13&P

e. CAPACITIES

Fuel Tank	8 quarts (7.6 L)
Cooking Pot	40 quarts (38 L)
Cooking Pot	60 quarts (56.8 L)

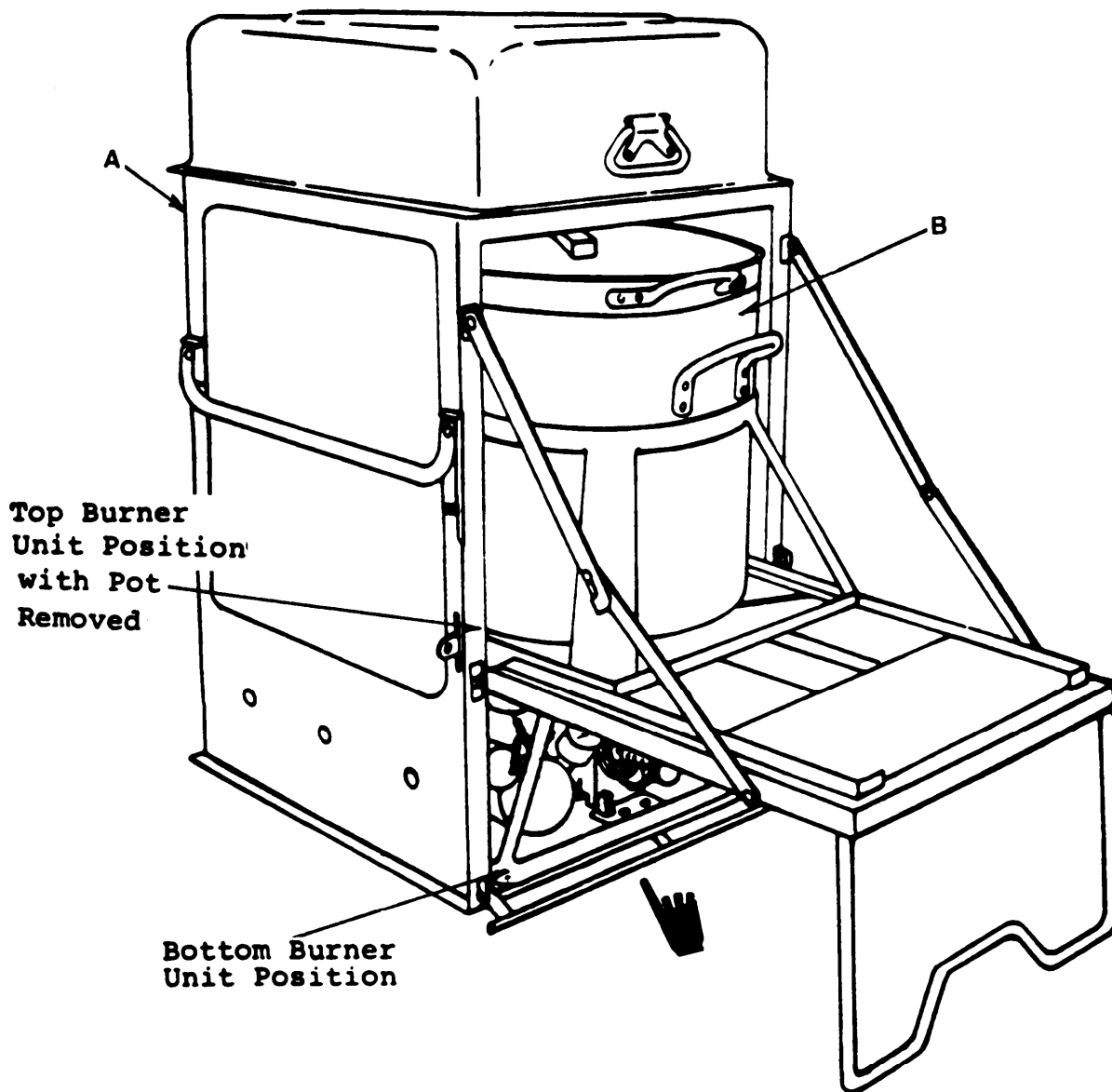

A. FIELD RANGE CABINET-When cabinet is used for cooking or baking, burner unit is placed in bottom position. When cabinet is used for frying the burner unit will be placed in top position.

B. COOKING POTS,

Figure 1-2. Location and Description of Range Outfit Major Components (Sheet 1 of 2).

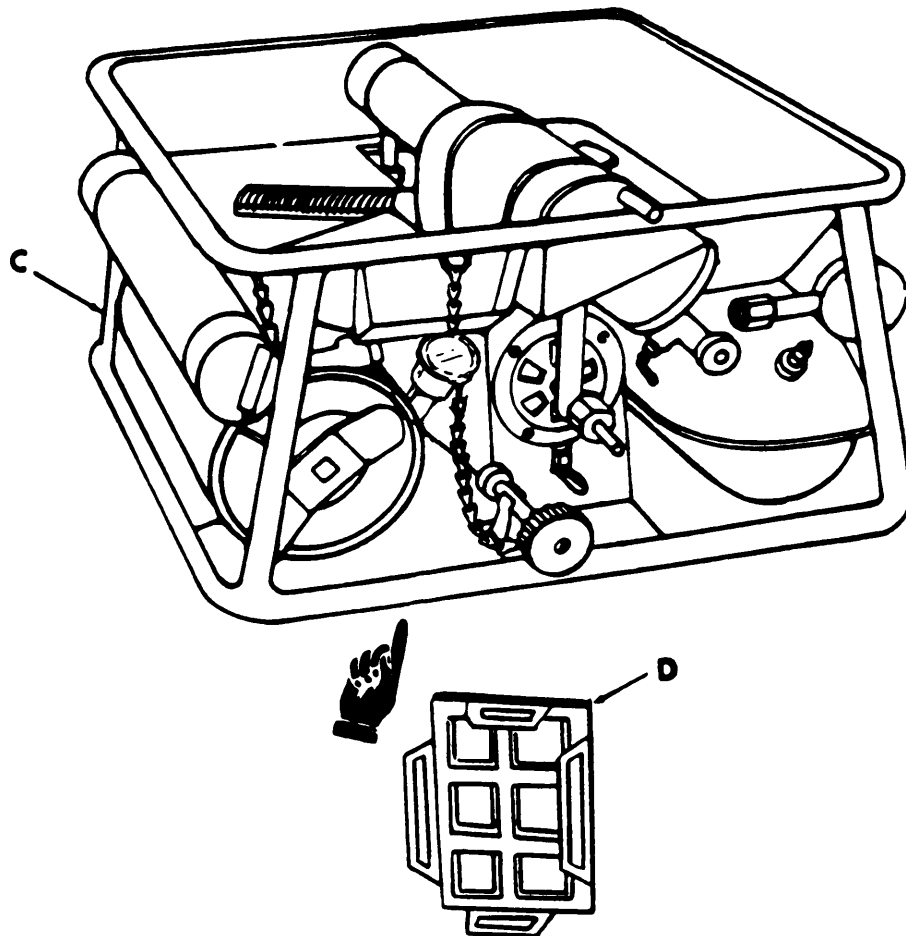

C. BURNER-Makes heat for cooking or baking and frying.

D. WARMER ADAPTER-Used to secure inserts from insulated food Container, which will adapt to the baking and roasting pan for Use as a warming table.

Figure I-2 Location and description of range Outfit Major components. (Sheet 2 of 2).

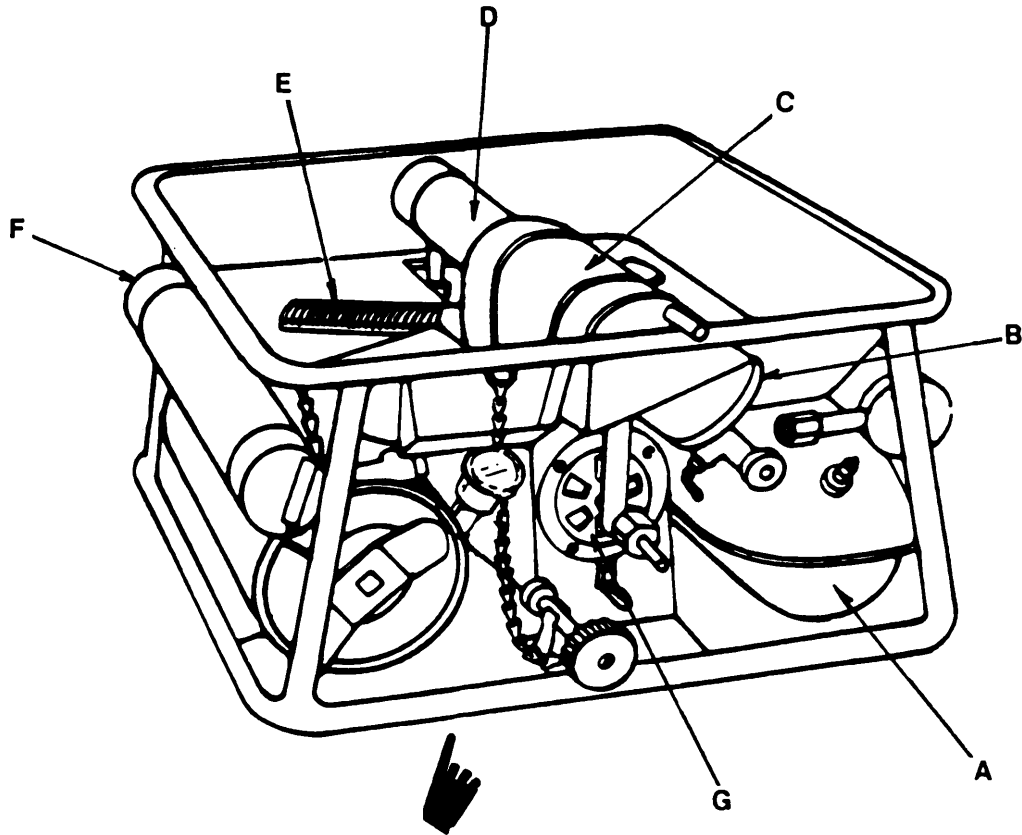

- A. FUEL TANK - Contains fuel to operate burner.
- B. PREHEATER Heats generator, which will then change fuel and gas vapor.
- C. PREHEATER SHIELD | Helps generator heat up faster.
- D. GENERATOR - Filters and converts liquid fuel into gas vapor.
- E. BURNER - Spreads out the flame undercooking pot or pans.
- F. SPARE GENERATOR= Replacement for defective generator.
- G. AIR SHUTTER - Adjusts air input to burner.

Figure 1-3. Location and Description of Burner Unit Major Components

f. DIMENSIONS AND WEIGHTS

(1) Range Cabinet	
Height	42 inches (106.7 cm)
Width	24 inches (61.0 cm)
Length	27 inches (68.6 cm)
Weight	114 pounds (51.76 kg)
(2) Burner Unit	
Height	10 inches (25.4 cm)
Length	23 inches (58.4 cm)
Width	19 inches (48.3 cm)
Weight (empty)	42 pounds (19.07 kg)
(3) Accessory Outfit	
Weight	39 pounds (17.7 kg)

g. FUEL CONSUMPTION

Normal Operation	2 quart (1.9 liters) /hour
------------------	----------------------------

Section III. TECHNICAL PRINCIPLES OF OPERATION**1-8 HOW IT WORKS.**

Fuel (gasoline) in the fuel tank is pressurized by a hand pump. The pressurized fuel is heated by a pre-heater, when hot the generator filters and turns the liquid fuel into a vapor. The vapor is ignited by a burner which produces heat under a cooking pot or baking rack.

CHAPTER 2

OPERATING INSTRUCTIONS

Section I. DESCRIPTION AND USE OF OPERATOR'S CONTROLS AND INDICATORS

2-1 GENERAL.

Figure 2-1 shows the location of the field range operator's controls and figure 2-2 shows the location of the burner operator's controls. Before you operate the range, make sure you know the location and operation of all controls.

2-2. GENERAL.

- a. Preventive Maintenance Checks and Services (PMCS, Table 2-1) are to be done to be sure the range is ready to use at all times. These checks and services help you find and fix defects before the range is damaged or fails.
- b. Item numbers in the first column of Table 2-1 indicate the order in which things are to be done. Each two "Interval" lists when to do them and who should do them.

NOTE

Number in item number column in table 2-1 is used in the "TM Number" column on DA Form 2404. Equipment Inspection and Maintenance Worksheet, in recording results of PMCS.

- c. If minor defects are found when the range is operating, take notes on what they are. Fix them or have them fixed after you have stopped operating the range.

CAUTION

While the range is operating, if any defect develops that you think will damage the range, stop it at once.

- d. Record all defects and steps taken to fix them on DA Form 2404 (Equipment Inspection and Maintenance Worksheet) as soon as possible.

Before you operate. Always keep in mind the WARNINGS and CAUTIONS located in this Technical Manual (TM). Perform your PMCS in accordance with Chapter IV, Section IV.

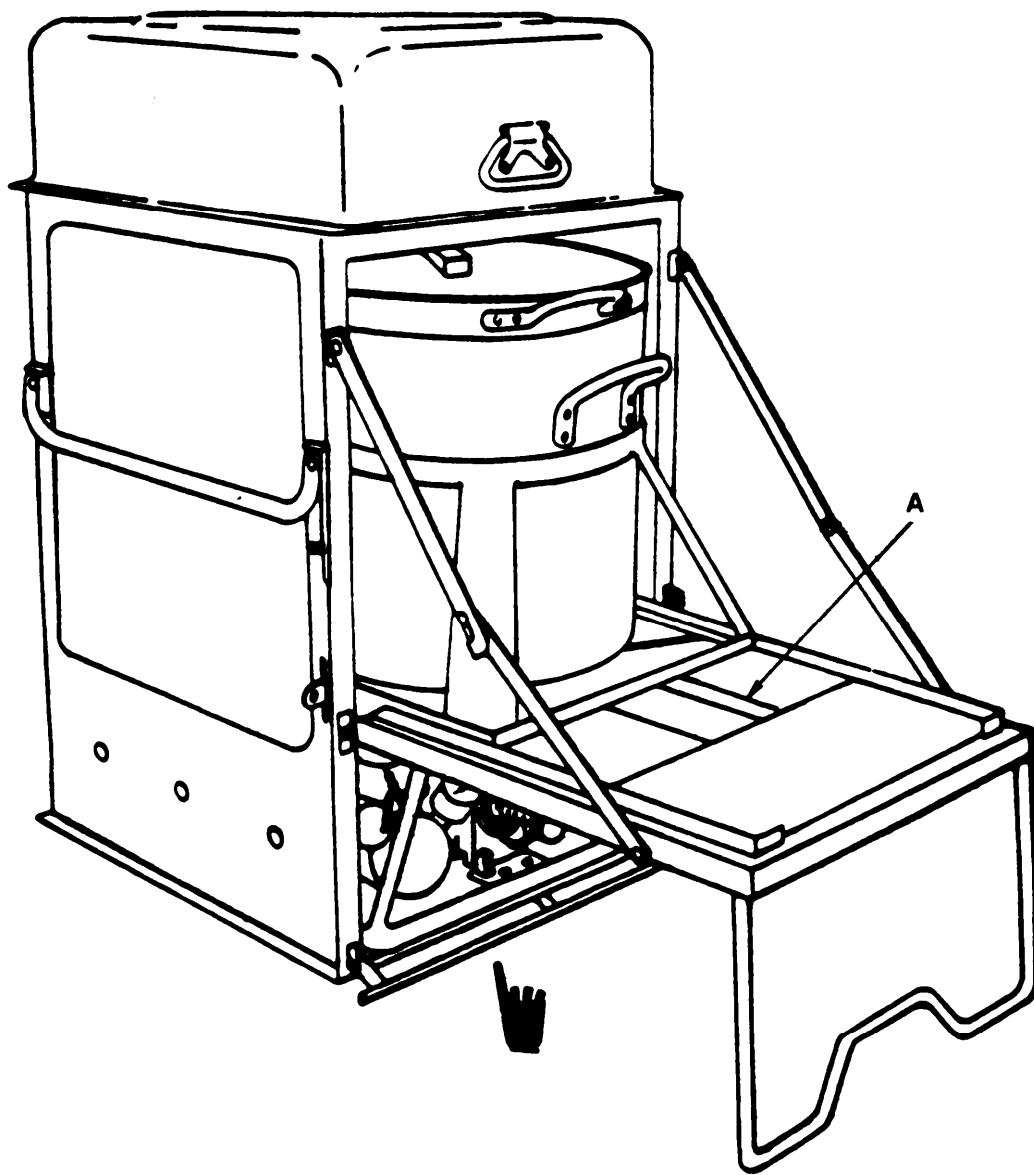

A. SHUTTER - Adjust air input to field range.

Figure 2-1. Operating Controls Field Range Outfit

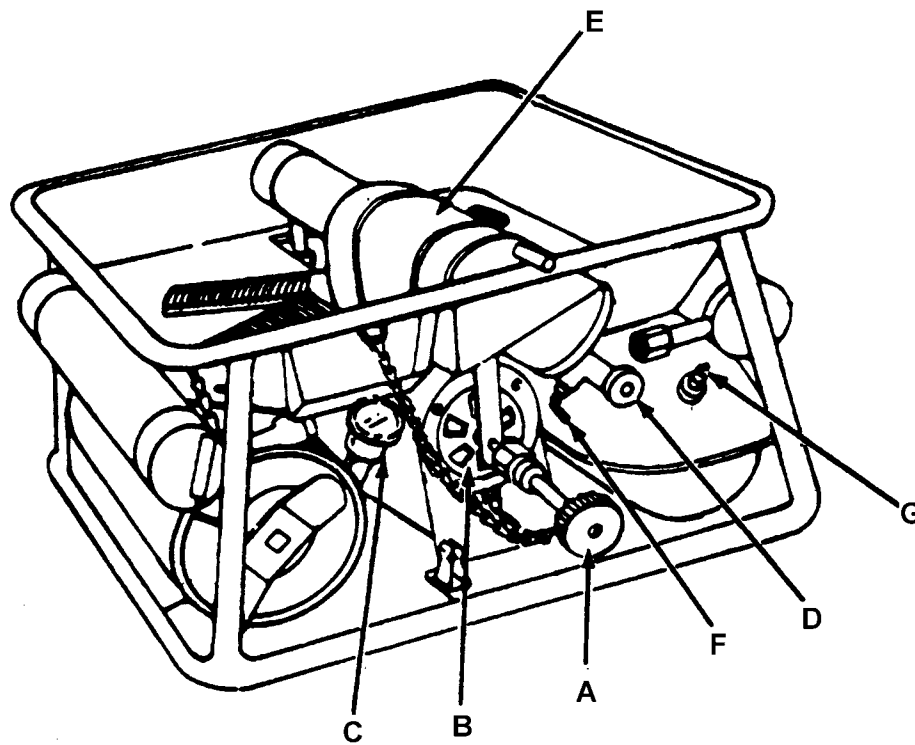

- A. **GENERATOR KNOB, FLAME VALVE** - Fuel adjustment to burner.
- B. **AIR CONTROL SHUTTER VALVE** - Air input adjustment to burner.
- C. **AIR PRESSURE GAGE** - Indicates pressure in fuel tank.
- D. **PREHEATER VALVE** - Inputs gas to preheater.
- E. **GENERATOR PREHEATER SHIELD** - Contains heat while gas is vaporizing.
- F. **ORIFICE CLEANER** - Cleans orifice in preheater valve.
- G. **AIR VALVE ASSEMBLY**- Hand pump attachment used to pressurize fuel tank.

Figure 2- 2. Operating Controls Burner

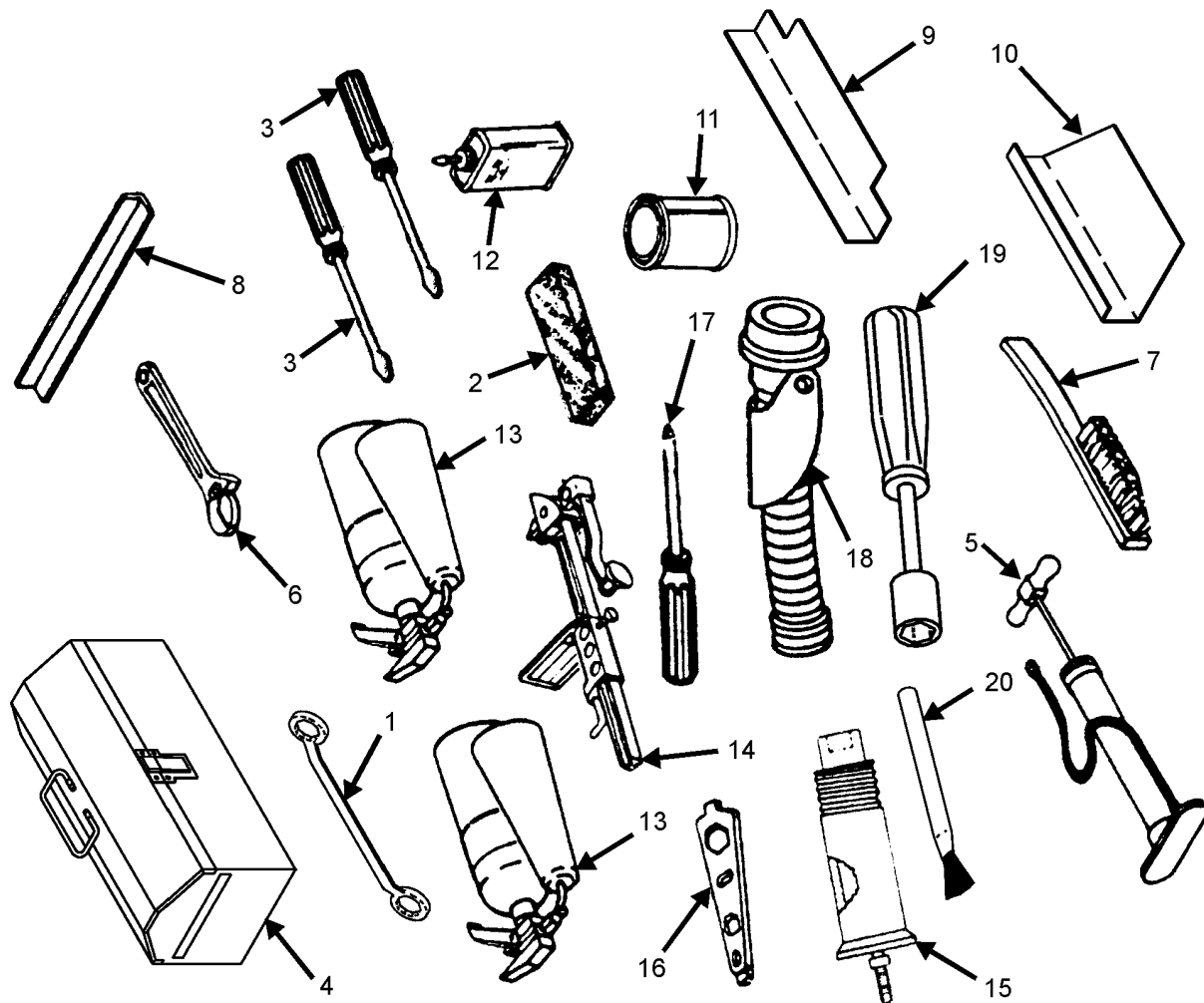

- | | | | |
|----------------------|-------------------|------------------------|----------------------------|
| 1. Box Wrench | 6. Wrench | 11. Antiseize compound | 16. Wrench |
| 2. Stone | 7. Brush | 12. Lubricating oil | 17. Screwdriver, Cross Tip |
| 3. Screwdriver, Flat | 8. Cleaner | 13. Fire extinguisher | 18. Spout |
| 4. Chest | 9. Protector Arm | 14. Opener | 19. Nutdriver, 7/16" * |
| 5. Pump | 10. Protector Arm | 15. Generator | 20. Brush Cleaning * |

* Used only with the Modern Burner Unit (MBU). For information on the Modern Burner Unit (MBU) refer to TM 10-7360-281-13&P.

Figure 2- 3. Field Range Accessories Outfit.

Table 2-1. Preventive Maintenance Checks and Services

B - Before operation

A - After operation

D - During operation

Item Number	Interval			ITEM TO BE INSPECTED PROCEDURE	Equipment is not ready/available if:
	B	D	A		
1	X	X	X	GENERAL - Inspect for holes, dents, broken welds, damaged rails or frame. Repair as required.	Cabinet needs repair.
2	X	X	X	LID - Inspect for improper closing, cracked or broken hinges (1), loose rivets (2), defective handle (3), bent lid brace (4), missing retaining pin (5), and missing wingnut (6). If repair or replacement is required refer to organizational or direct support maintenance.	Lid needs repair.

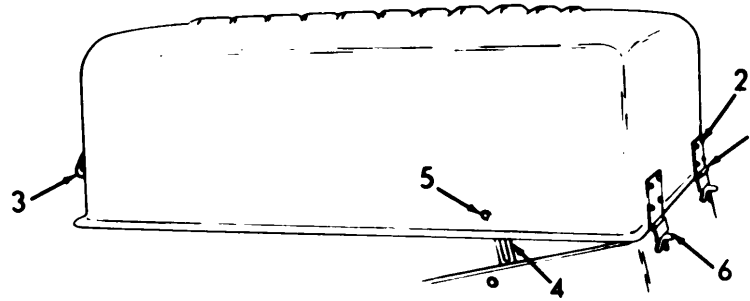

Table 2-1. Preventive Maintenance Checks and Services

B - Before operation

A - After operation

D - During operation

Item Number	Interval			ITEM TO BE INSPECTED PROCEDURE	Equipment is not ready/available if:
	B	D	A		
3	X	X	X	 <p>DOOR - Inspect door (7), and door rest (8), hinge (9) for proper closing. Inspect upper and lower stays (10) for binds and binding. Inspect shutter slide (11) and guide for damage. If repair or replacement is required refer to direct support maintenance.</p>	Door needs repair.

Table 2-1. Preventive Maintenance Checks and Services

B - Before operation

A - After operation

D - During operation

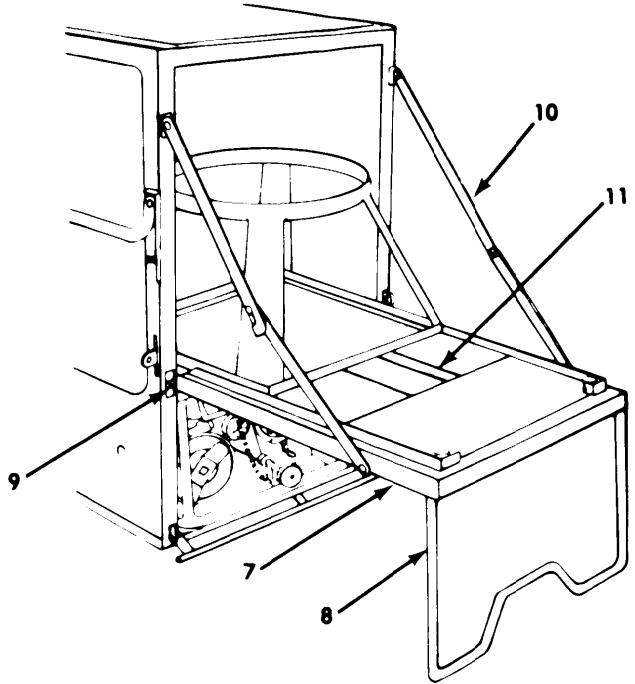
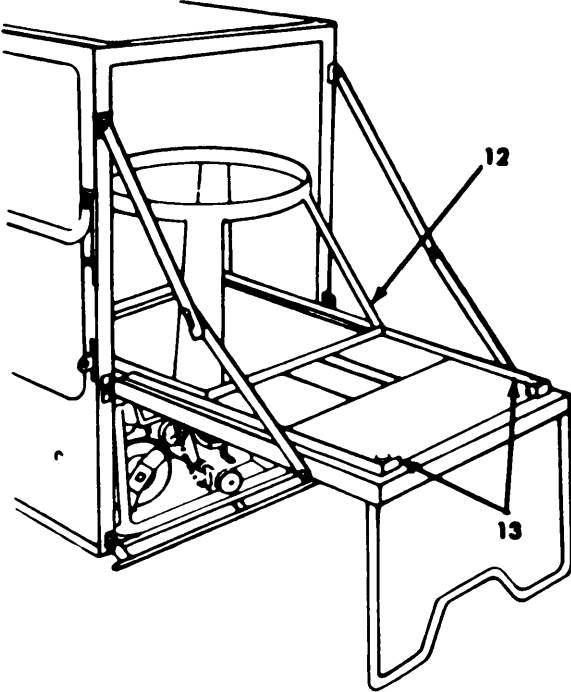
Item Number	Interval			ITEM TO BE INSPECTED PROCEDURE	Equipment is not ready/available if:
	B	D	A		
4	X	X	X	 <p>CRADLE - Inspect cradle (12) for signs of damage. Inspect left and right side of cradle slide (13) for damage. If repair or replacement is required refer to organizational maintenance.</p>	Cradle needs repair.
5	X		X	<p>ACCESSORY OUTFIT</p> <p>ACCESSORY OUTFIT - Inspect for missing or damaged items. Replace as necessary. Refer to figure 2-3.</p>	Accessory outfit short air pump/fire extinguisher.

Change 5 2-7

TM 10-7360-204-13&P

Table 2-1. Preventive Maintenance Checks and Services—Continued

Item Number	Interval			ITEM TO BE INSPECTED PROCEDURE	Equipment is not ready/available if:
	B	D	A		
6	X			<p>BURNER UNIT</p>  <p>Fuel Tank—Check for leaks in fuel tank (14) and damaged fuel filler cap (15). Pressure test the burner unit in area 50 feet away from gasoline and cooking area. Do not smoke, and make sure there is no open flame in the vicinity. Place unit in horizontal position. Hand pump the pressure in the fuel tank to 6 to 8 pounds per square inch (PSI). Remove pump and replace air valve cap. Check for leaks with soapy water. To release air pressure, place unit in vertical position, turn fuel filler cap slowly counter-clockwise.</p>	Fuel tank needs repair or replacement.
7	X	X			



Table 2-1. Preventive Maintenance Checks and Services - Continued

B - Before operation

A - After operation

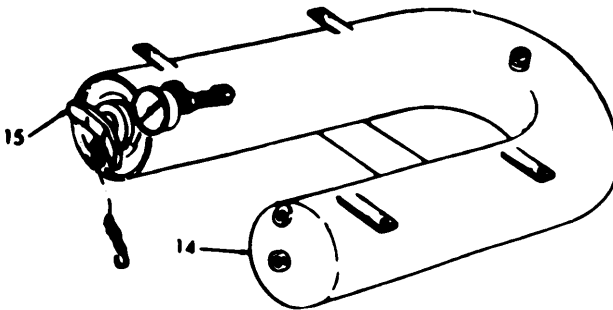
D - During operation

Item Number	Interval			ITEM TO BE INSPECTED PROCEDURE	Equipment is not ready/available if:
	B	D	A		
8	X			 <p>GENERATOR - Inspect and service generator (18) and flame valve and knob (19) for damage. If replacement is required refer to organizational maintenance.</p>	Generator needs repair or replacement.
9	X	X	X	 <p>AIR SHUTTER - Inspect air shutter (20) and control lever (21) for damage. Repair as necessary.</p>	Air shutter needs repair.

Table 2-1. Preventive Maintenance Checks and Services – continued

Item Number	Interval			ITEM TO BE INSPECTED PROCEDURE	Equipment is not ready/available if:
	B	D	A		
10	X		X	 <p>AIR PRESSURE GAUGE – Inspect pressure gauge (22) for damage and broken glass. If test or repair is required, refer to organizational maintenance.</p>	Glass is broken or gauge is defective.
11	X			 <p>AIR VALVE ASSEMBLY – Inspect air valve assembly (23) for damage. If service or repair is required, refer to organizational maintenance.</p>	Air Valve needs replacement.

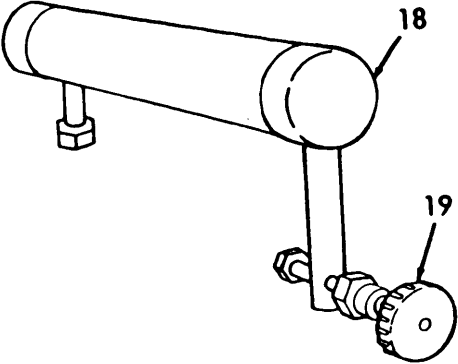
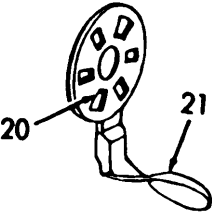
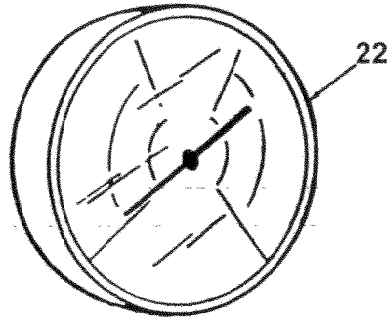
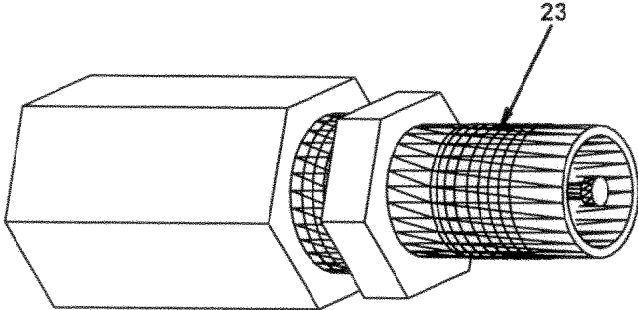

2- 3. CLEANING.

a. Cabinet.

(1) Clean cabinet with soap and hot water or dry cleaning solvent P-D-680 (item 5, Table F- 1). Do not use abrasive cleaners or wire brushes. A commercial type nylon cleaning pad may be used to remove corrosion or caked-on grease.

(2) Check the cabinet for signs of corroding or peeling. The coating over the metal may show spots. If so, remove them with soap and hot water or dry cleaning solvent P-D-680 (item 5, Table F-1). Nylon cleaning pad may be used. Check to be sure braces, angle irons, and support parts are fastened tight. Make sure everything works: try latch pins, shutters, door latches and rest, lift handles, and inner rack sets. A wooden match or toothpick can help get accumulations out of places like bracket joints, spring and pin assemblies, and rivet seats.

b. Utensils. Clean utensils with hot water and soap. Scouring will spoil the utensils' finish. All standard items are coated with the same preservative compound as the cabinet. Wrap each utensil individually in a barrier material (item 3, Table F-1).

Section II. OPERATION UNDER USUAL CONDITIONS

2- 4. GENERAL.

The instructions in this section are for personnel who operate the range. It describes how the burner is started and stopped in normal weather conditions.

2- 5. ASSEMBLY AND PREPARATION FOR USE.

2- 5.1. UNLOADING THE EQUIPMENT.

The total weight of the field range outfit is 295 pounds (133.9 kg). A handtruck, forklift, or manpower may be used to unload the outfit. The outfit must be kept in an upright position while unloading.

2- 5.2. UNPACKING THE EQUIPMENT.

a. General.

CAUTION

Be careful while unpacking to avoid damage to the equipment.

b. Unpacking. Cut and remove all retaining straps. Remove the burner. Open the door and remove the kitchen utensils from the cabinet.

c. Fire Extinguisher. Mount the fire extinguisher where it will be available for immediate use.

d. Depreservation. Remove all protective tape and coverings. Prepare the unit for inspection and operation as outlined in DA Form 2258 (Depreservation Guide for Vehicles and Equipment).

2 5.3. INSPECTING THE EQUIPMENT.

a. Check identification plate against packing bill for positive identification of equipment.

b. Visually inspect equipment for any damage which may have occurred during shipment.

2-5.4. INSTALLATION AND SERVICING THE EQUIPMENT.

a. Installation.

(1) Install the field range outfit on a level site, clear of obstacles and, if indoors, allow for ample ventilation.

(2) For field operation avoid, if possible, dusty or sandy conditions. Use gravel or other suitable material for a base where the ground is soft or wet.

WARNING

Do not use flammable material for a base.

(3) When the requirement exists to use two or more ranges (figure 2-4), place the second unit so that its two junction lugs are aligned with the two junction brackets on the first unit. Join the two units with the two latch pins.

b. Service.

(1) Remove kitchen utensils (pots, pans, etc.) from cabinet, wash in hot soapy water, rinse in clear boiling water, and air dry. Place in a clean, enclosed area near the range.

(2) Remove burner (figure 2-5) by lifting up on retaining bar and pulling forward lowering the bar. The burner unit can then be pulled forward from the cabinet.

(3) Clean inside and outside of range with hot soapy water, rinse in clear boiling water and air dry.

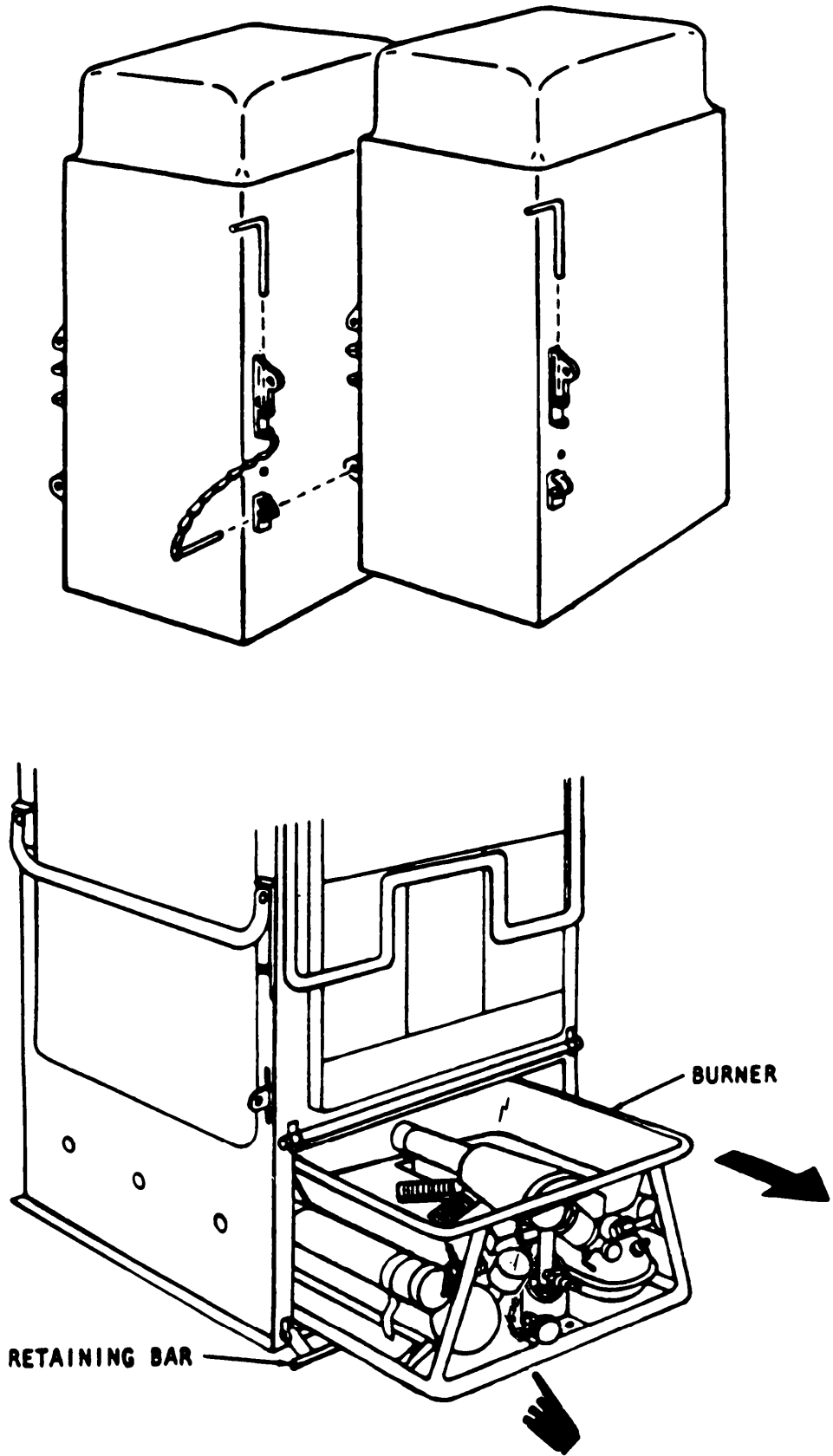

Figure 2-5. Burner Removal

(4) *Clean* the burner by wire brushing (figure 2-3, item 7). Run cleaner (figure 2-3, item 8) by rocking motion through slots to remove any burned on dirt. Refer to figure 2-6.

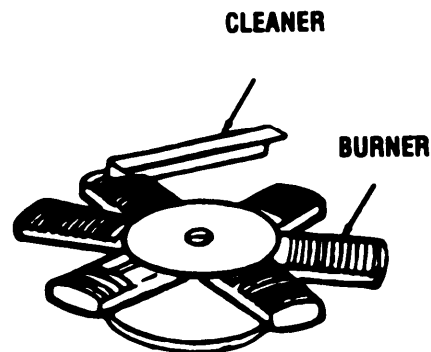

Figure 2-6. Burner Cleaning.

(5) *Close* preheater and generator valves (figure 2-7) by turning clockwise.

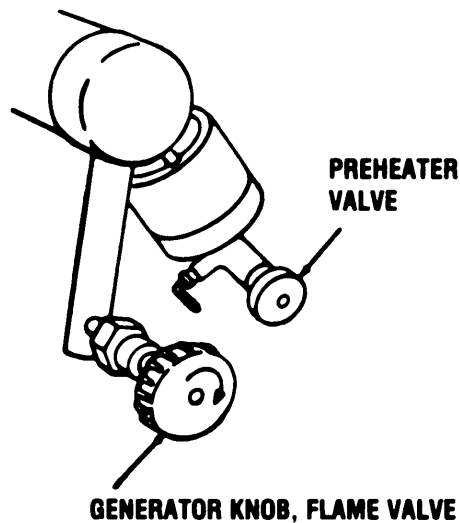
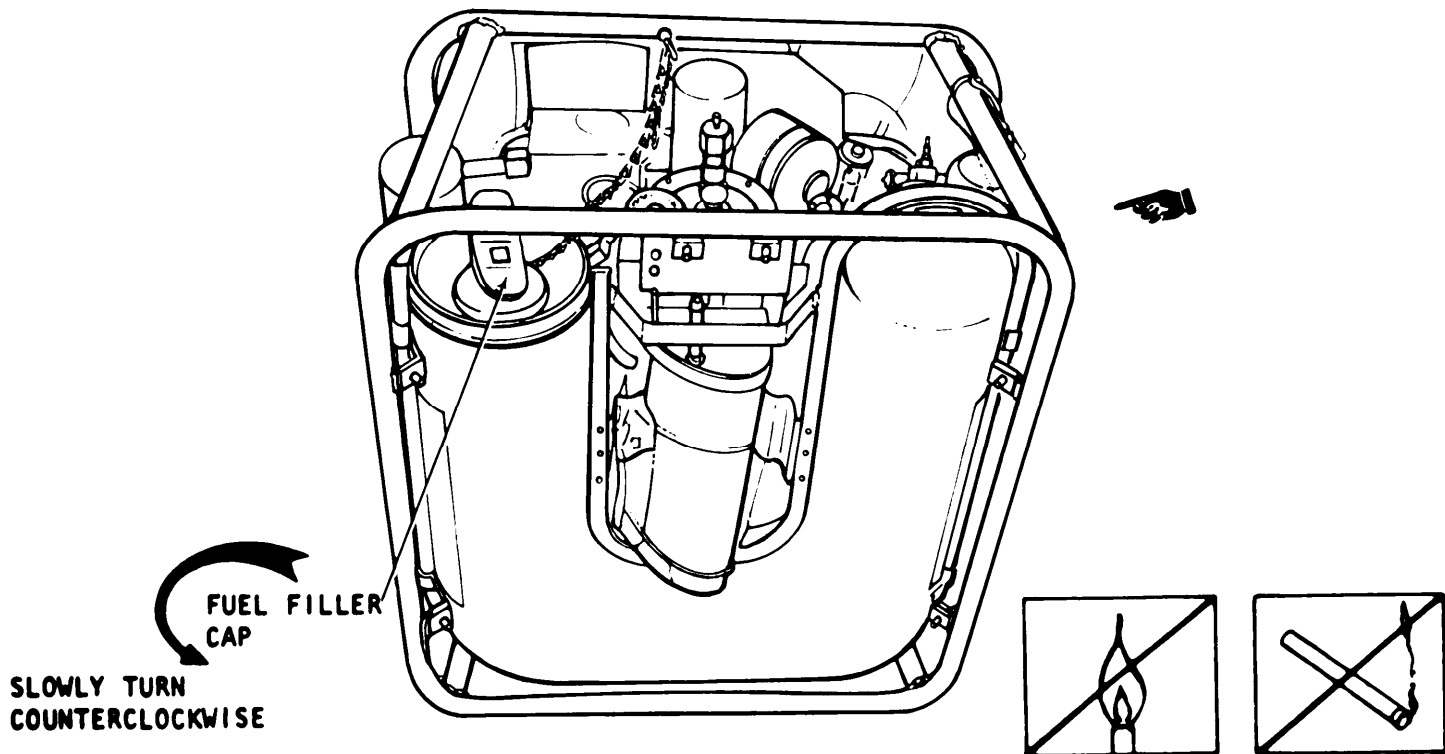
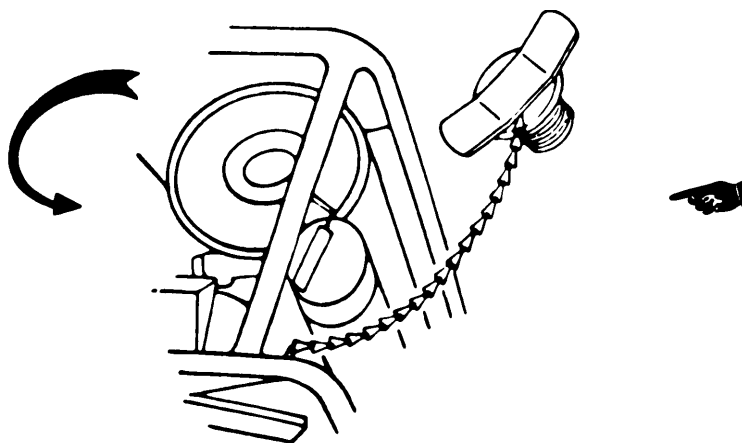

Figure 2-7. Closing Valves.

(6) Take burner unit to the fueling area not less than 50 feet away from the lighting and cooking areas. Place unit on back end in vertical position (Fig. 2-8). Release air pressure by turning fuel filler cap slowly counterclockwise. After air pressure is released, remove filler cap.



A. Releasing air pressure.



B. Cap removed.

Figure 2-8. Servicing Fuel Tank (Sheet 1 of 2).

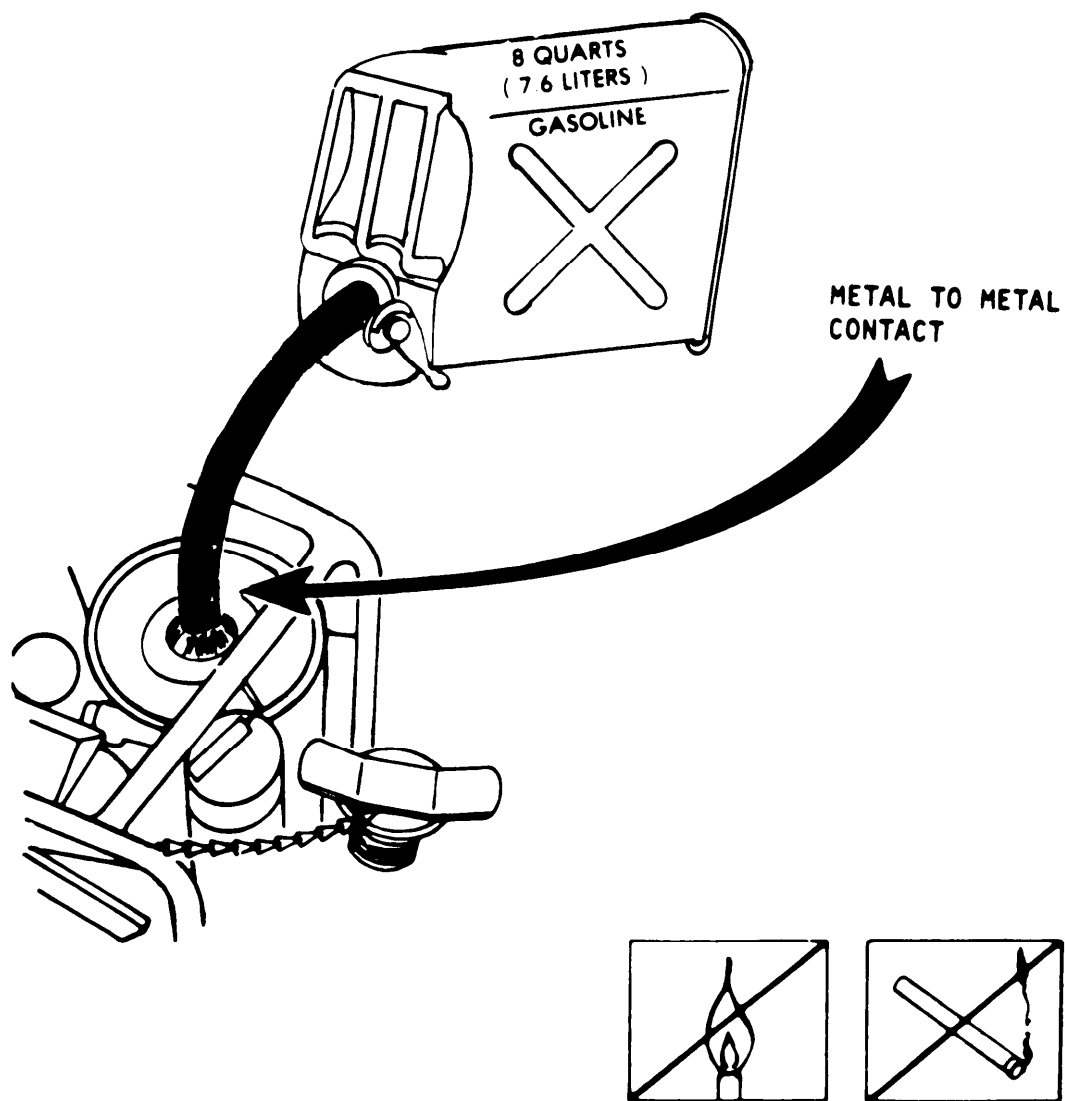

C. Filling tank

Figure 2-8 Servicing Fuel Tank (Sheet 2 of 2).

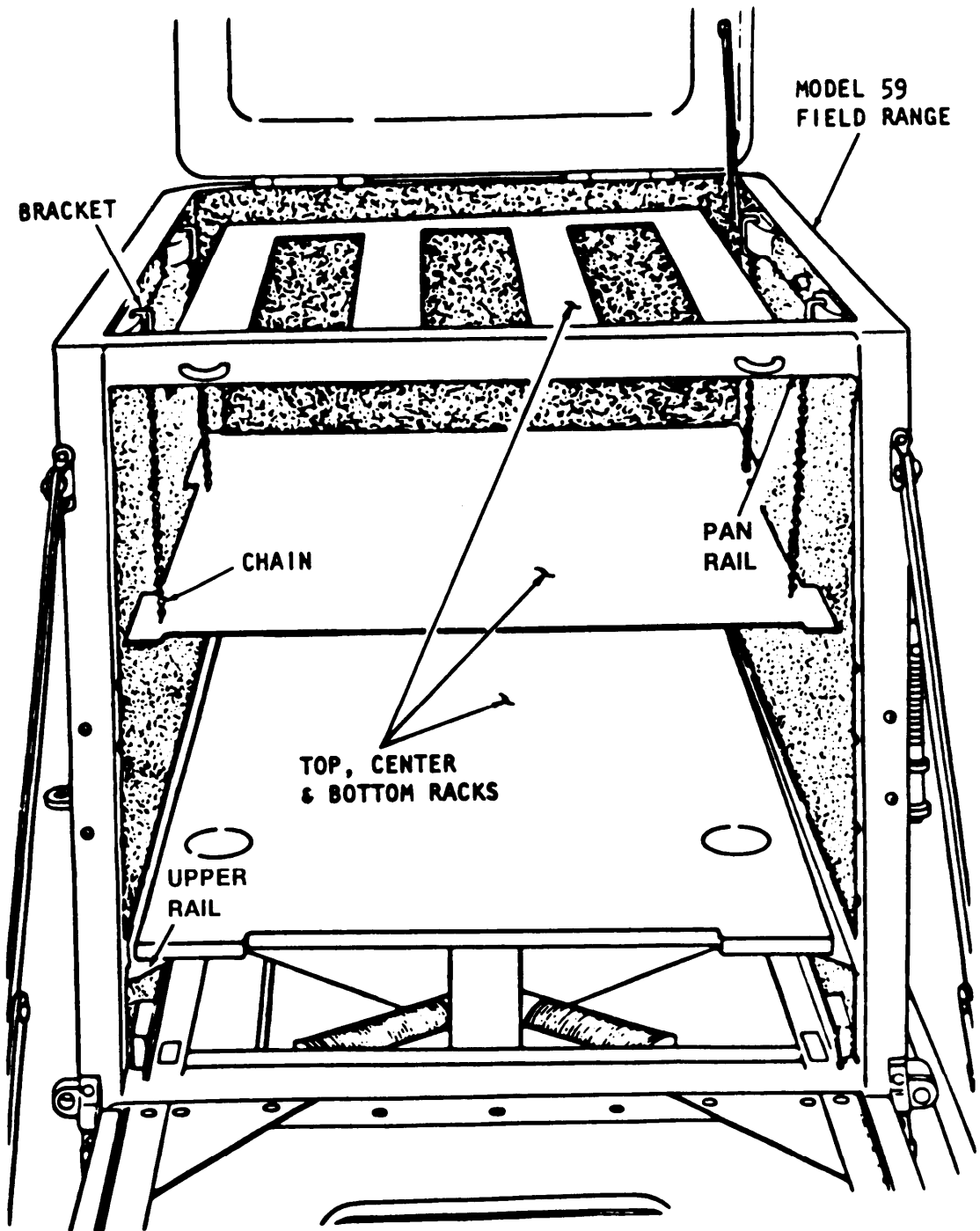

Figure 2-9. Baking Rack set, removal and Replacement

WARNING

When filling the fuel tank, do not smoke, and make sure there is no open flame in the vicinity. Provide a metal-to-metal contact between the fuel tank and the container. This will prevent a spark from being generated

(7) Fill the fuel tank with **8** quarts (**7.6** liters) gasoline (item 2, Table F-1) or until fuel can be seen at the bottom of the fuel filler tube. Eight quarts of gasoline will burn for approximately 4 hours. Replace filler cap and hand tighten.

2-5.5 BAKING RACK SET.

a. *General.* Racks are required for baking in the field range outfit. The rack set consists of three racks.

b. *Removal.*

(1) Remove top bake rack by simply lifting it off of the pan roll.

(2) The center bake rack is removed by removing the supporting chains from the brackets.

(3) The bottom bake rack is removed by pulling it forward on the upper rail until it is clear of the cabinet.

c. *Replacement.* The bake racks are to be replaced by reversing the procedure used in removing them.

2-6. STARTING THE EQUIPMENT.

a. *Before you operate.* Always keep in mind the CAUTIONS and WARNINGS and closely follow these instructions.

b. *Preparation for Starting.*

(1) Do the before operations preventive maintenance services (para 2-2).

(2) Take the burner unit to an area 50 feet away from any open flame. Place unit in horizontal position.

(3) Remove air valve cap. Pump hand pump until pressure gage reads 6 to 8 pounds per square inch (psi). Remove pump and replace air valve cap. Check for leaks with soapy water.

(4) Take burner unit to the established lighting area that is a minimum of 50 feet from the refueling, fuel storage and cooking areas.

AIR PRESSURE GAUGE

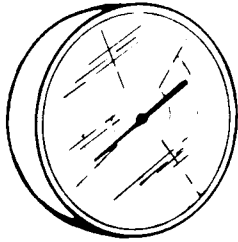

HAND PUMP

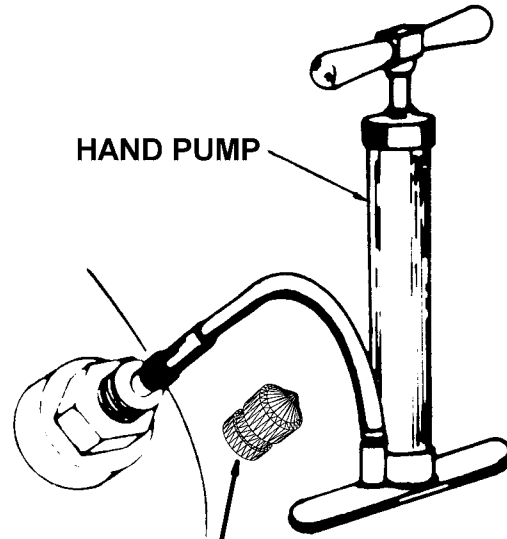

AIR VALVE CAP

(5) Turn orifice cleaning control completely around 2 or 3 times. When done, handle will point down.

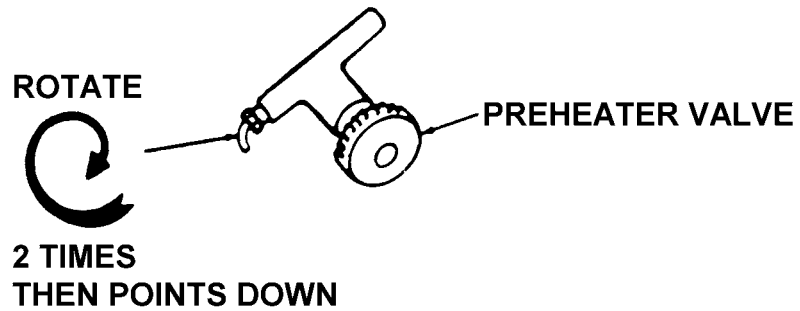

b - Preheater cleaning control

(6) Place lighted match close to preheater head and turn preheater valve one-quarter turn counterclockwise and ignite. Allow to burn 5 to 7 seconds or until flame burns evenly. Turn preheater valve fully counterclockwise.

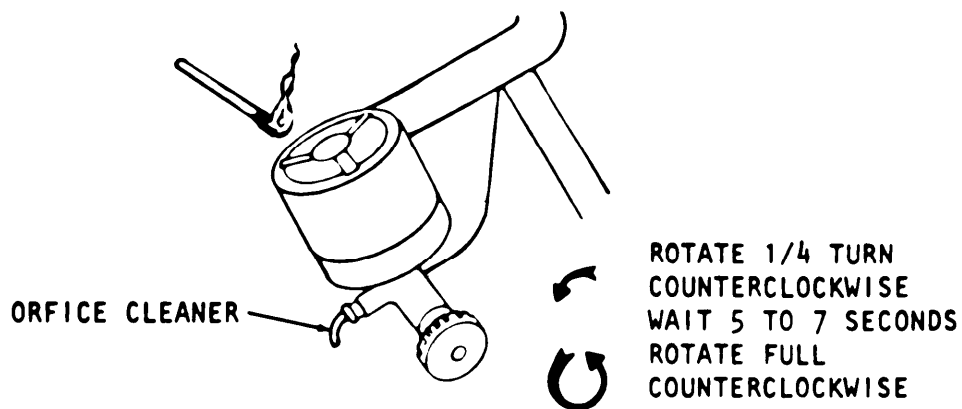

(7) Place preheater shield over preheater.

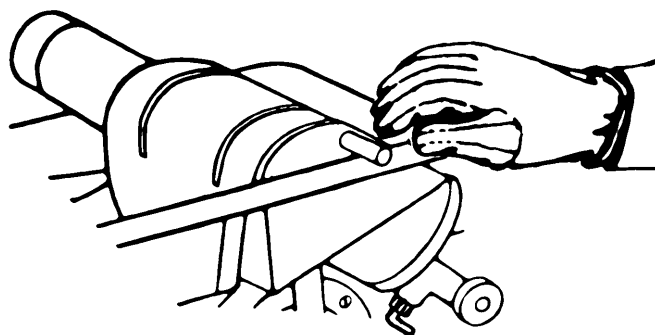

WARNING

The shield is hot: handling may cause injury. Heater shield should be handled with care. Use glove to protect from injury.

(8) Allow preheater to burn 10 minutes or until back end of generator is hot to touch.

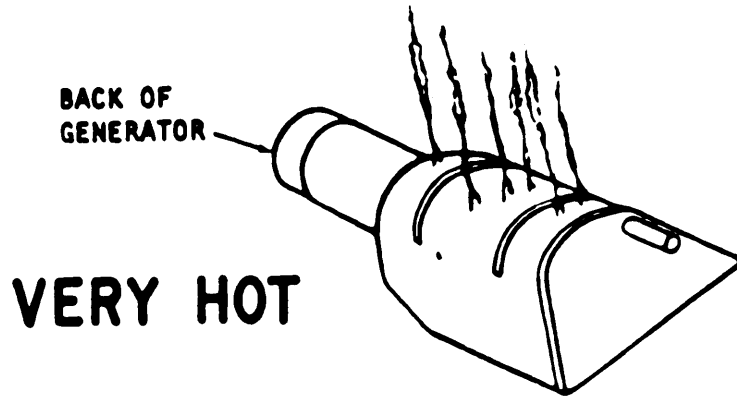

(9) Operate air control shutter lever to a half-open position.



(10) Remove flame valve knob from holder and place on valve. Slowly turn flame valve knob counter clockwise to a full open position.

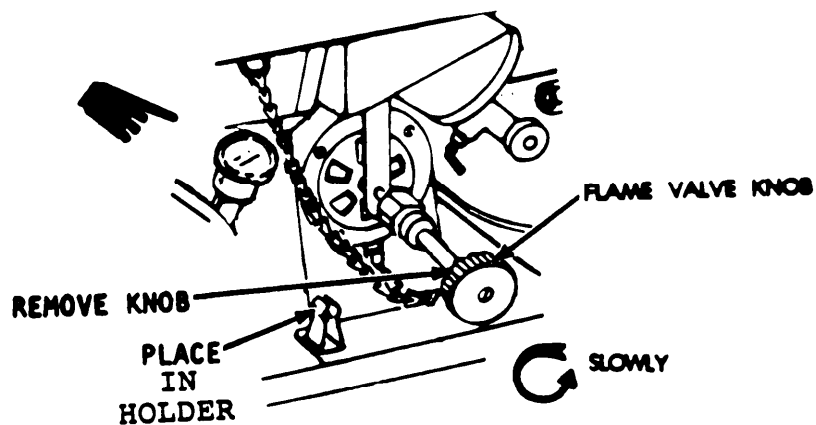

NOTE

The burner will ignite when the flame valve is about half-open.

(11) The burner will ignite. When lit remove the preheater shield. Use glove to protect from injury.

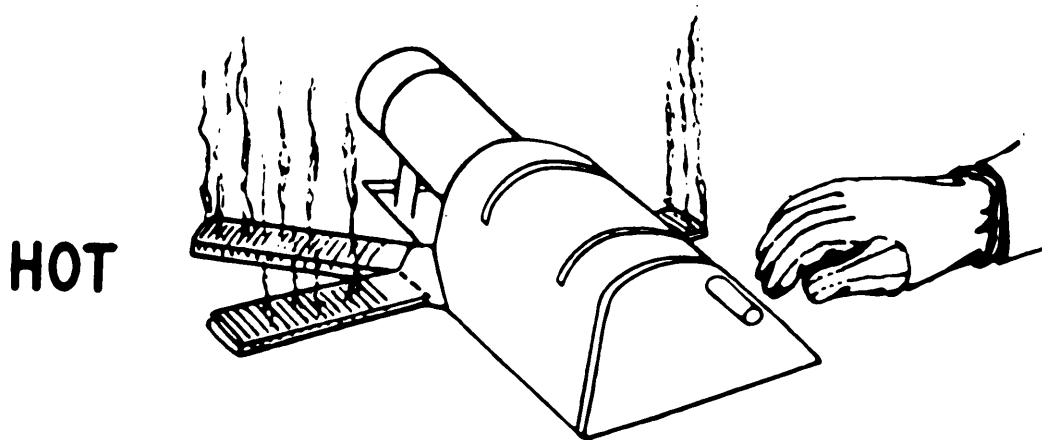

(12) Shut the preheater valve by turning full clockwise.

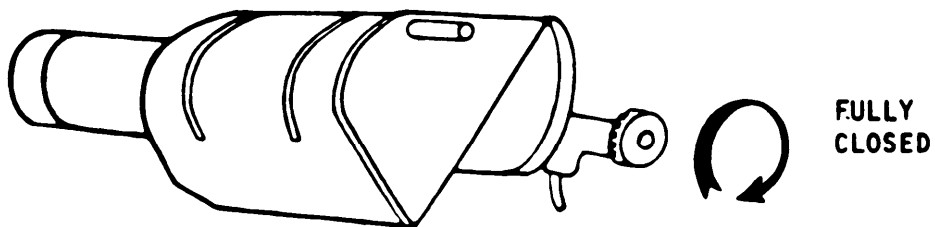

(13) Turn flame valve clockwise until flame lowers to height of generator. Adjust air shutter until flame is green in color. Place flame valve knob back in holder.

- (14) Carry burner unit to cooking area.

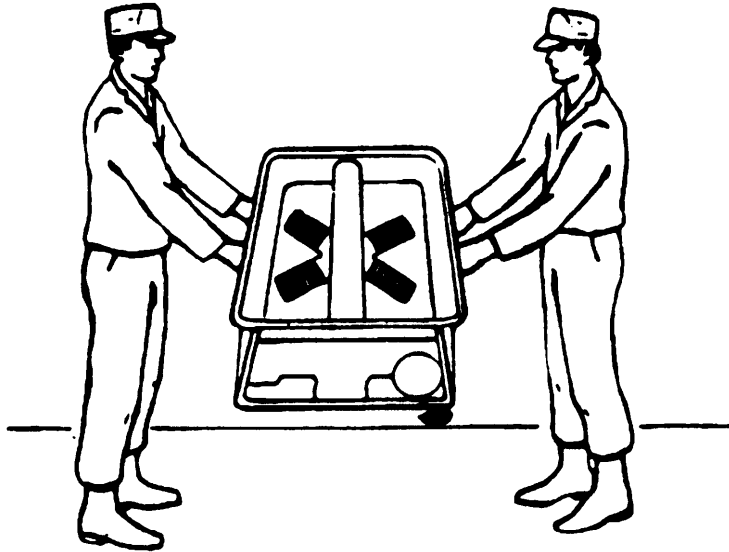

(14A)



Never put more than one burner unit in the field range cabinet. Before placing a burner unit in either cabinet position, check to be sure the other position is empty. Operating a range with two burner units could lead to injury or death.

Select upper or lower burner unit position in cabinet. Lower door or retainer bar as required. Insert burner unit into cabinet position selected.

- (15) Remove flame valve knob from holder and place on valve. Readjust height of flame and air shutter until desired cooking temperature is reached. Remove flame valve knob and place in holder. Close door or secure retainer bar as required.

**REMOVE FLAME VALVE
KNOB AND PLACE IN
HOLDER**

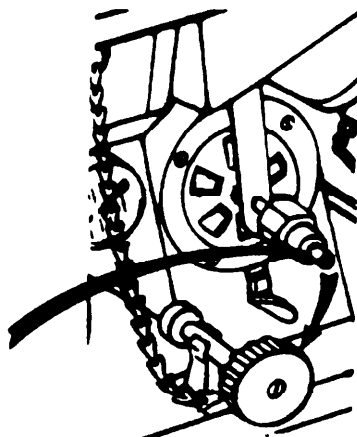

(16) Operating pressure on gage is between 6 and 20 psi.

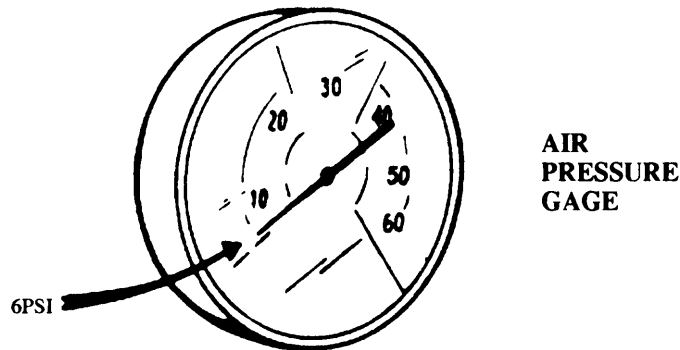

CAUTION

If pressure on gage reads between 20-25 psi, turn flame down to about one-half size, and continue operation for 1/2 hour. If pressure increases, beyond 25 psig, turn unit off, remove from cabinet, and allow to cool before placing back in operation.

NOTE

Safety valve device is installed to prevent pressure buildup over 60 psig, will bleed off into the mixing chamber.

2-7. STOPPING THE EQUIPMENT.



Do not release the fuel tank air pressure while the unit is lit, while smoking or near an open flame.

- a. Remove the flame valve knob from the holder and place on the generator valve stem. Turn the knob clockwise until tight. Remove flame valve knob and replace in holder. Allow cabinet and burner unit to cool.
- b. If necessary to remove an unlit hot burner unit from the cabinet to an outside cooling area, use a two person carry. Wear heat protective gloves.

2-8. DISMANTLING FOR MOVEMENT.

- a. *If the unit is to be moved from the immediate vicinity, provide adequate cushioning material for loose components and accessories inside the cabinet.*



Allow components such as pots, pans, griddle, etc. to cool before stowing them in the field range cabinet.

- b. Stow all components and accessories in their proper containers. and stow components and containers in the field range cabinet. Secure cabinet door.

WARNING

**Allow the unit to cool before releasing the air pressure from fuel tank.
Do not smoke, and make sure there is no open flame in the vicinity.**

- c.* Remove burner unit from cabinet and release fuel tank air pressure. To release air pressure, place unit in vertical position, and turn fuel filler cap slowly counterclockwise.
- d.* Install the burner unit in the bottom burner unit position and secure with retaining bar.
- e.* If the range outfit is installed as a multiple unit, and the equipment is to be moved some distance, separate the range into individual units and handle them separately.

2-9. REINSTALLATION AFTER MOVEMENT.

Refer to paragraph 2-1 to reinstall the equipment.

Section III. OPERATION UNDER UNUSUAL CONDITIONS

2-10. GENERAL.

This section contains instructions for operation of the equipment in the following conditions: extreme cold, extreme heat, dusty or sandy areas, rainy or humid conditions, salt water areas, and high altitudes.

2-11. OPERATION IN EXTREME COLD (BELOW 0 °F).

- a.* Initial tank pressure may need to be pumped until pressure reads 8 pounds per square inch (psi) as indicated on the air pressure gauge.
- b.* Keep the fuel tanks filled with 8 quarts (7.6 liters) of gasoline or until fuel can be seen at the bottom of the fuel filler tube, when the burner unit is vertical and not in operation. This will help to prevent moisture from accumulating in the fuel tank.
- c.* A flat rubber filler cap gasket must be used for cold weather applications. Filler Cap Gasket installation is an Organizational Maintenance procedure (paragraph 4-9.8).
- d.* Adjust the air control shutter as required to insure a greenish color flame.
- e.* Remove any accumulation of moisture at regular intervals.

2-12. OPERATION IN EXTREME HEAT.

- a.* Never place more than 8 quarts (7.6 liters) of gasoline in the burner unit. The unit is properly filled when the fuel can just be seen at the bottom of the fuel filler tube. Overfilling does not leave sufficient space for expansion. During extreme heat tank pressure may be pumped to 3 to 5 psi on gauge.
- b.* If the unit is to be operated indoors, provide adequate ventilation.
- c.* Observe the air pressure gage often.

2-13. OPERATION IN DUSTY OR SANDY AREAS.

- a.* Erect a protective shelter for the unit where possible. In temporary installations, take advantage of natural barriers.
- b.* Where water is available, keep the immediate area wetted down. Keep the unit and accessories as clean as possible; pay special attention to the burner unit and utensils.
- c.* Keep dirt and grit out of the fuel system and reserve fuel supply.

2-14. OPERATION UNDER RAINY OR HUMID CONDITIONS.

When the equipment is operated outdoors, erect a shelter if possible. When not in use, the unit will be covered with canvas or other waterproof material. Remove the cover during dry periods, open the doors, and allow the unit to dry out. Keep the fuel tank filled with 8 quarts (7.6 liters) of fuel.

2-15. OPERATION IN SALT WATER AREAS.

- a. Keep equipment free of contact with salt water whenever possible. If contact is made, or if equipment is exposed to salt spray, wash equipment frequently with clean fresh water.
- b. Coat exposed surfaces of the range cabinet and burner assembly with corrosion preventive compound, P-14, (item 1, Table F-1).

2-16. OPERATION IN HIGH ALTITUDES.

Inspect the air pressure gage at more frequent intervals. Adjust the air control shutter as needed to compensate for air pressure changes.

CHAPTER 3

OPERATOR MAINTENANCE INSTRUCTIONS

Section I. LUBRICATION INSTRUCTIONS

3-1 GENERAL.

The range has a small number of moving parts. The lubrication required is described in para 3-2.

3-2. DETAILED LUBRICATION INSTRUCTIONS.

a. Cradle Rails—Lubricate cradle rails in cabinet and on cabinet door with antiseize compound to prevent the cooking pot cradle from sticking.

b. Hinges—Lubricate hinges on cabinet door, lift handles, middle joint on door stays, racks for sliding shutters on the cabinet door with general purpose oil.

Section II. TROUBLESHOOTING

3-3. GENERAL.

a. Table 3-1 lists the common malfunctions which you will find during the operation or maintenance of the range outfit. You should perform the tests/inspections and corrective actions in the order listed.

b. This manual cannot list all malfunctions that may occur or all tests or inspections and corrective actions. If a malfunction is not listed or is not corrected by listed corrective actions, notify your supervisor.

NOTE

Before you use this table, be sure you have performed all operating checks.

TABLE 3.1. OPERATOR TROUBLESHOOTING

MALFUNCTION	TEST OR INSPECTION	CORRECTIVE ACTION
1. FUEL SYSTEM FAILS TO MAINTAIN PRESSURE.		
Step 1.	Fuel filler cap loose.	Tighten cap.
Step 2.	Fuel Drain plug is loose.	Tighten plug.
Step 3.	Generator valve left open.	Close valve.
Step 4.	Preheater valve left open.	Close valve.
Step 5.	Generator connections not tight.	Tighten connections.
Step 6.	Pressure gage not secure in tank.	Tighten gage.
Step 7.	Air valve assembly not secure to tank.	Tighten valve.
Step 8.	Safety valve does not reseal.	Refer to org maint.

TABLE 3-1. OPERATOR TROUBLESHOOTING—Continued

MALFUNCTION	TEST OR INSPECTION	CORRECTIVE ACTION
2. PREHEATER FAILS TO IGNITE.		
Step 1. Orifice is clogged.		Clean orifice.
Step 2. Low air pressure.		Pressurize fuel system.
Step 3. Dirty or contaminated fuel.		Shut down—clean and replace fuel.
3. BURNER FAILS TO IGNITE.		
Step 1. Low air pressure.		Pressurize fuel system.
Step 2. Insufficient fuel supply.		Fill fuel tank.
Step 3. Generator insufficiently preheated.		Preheat generator for longer period of time.
Step 4. Feed tube assembly missing, clogged or dented.		Shut down—allow to cool—clean feed tube assembly or have replaced.
4. YELLOW BURNER FLAME.		
Step 1. Air control shutter improperly adjusted.		Adjust shutter.
Step 2. Mixing chamber flooded.		Turn off generator flame valve, allow flame to burn out, and relight burner.
5. BLUE BURNER FLAME.		
Air control shutter improperly adjusted.		Adjust shutter.
6. BURNER FLAME TOO LOW.		
Step 1. Flame valve adjusted too low.		Open flame valve slightly.
Step 2. Insufficient fuel supply or defective generator.		Allow to cool—replace fuel and/or generator.
NOTE		
<i>Do not overfdl, 8 quarts (7.6 liters) required.</i>		
Step 3. Generator flame valve orifice unit is partly clogged.		Turn off flame valve, allow flame to burn out, and relight the burner.
7. BURNER FLAME UNEVEN.		
Slots in burner arm clogged.		Clean burner slots.

Section III. MAINTENANCE PROCEDURES

3-4. GENERAL.

This section contains the operator maintenance procedures for repair of the M2, M2A and the M2A with Safety Device generators. Refer to TM 10-7360-281-13&P operator maintenance procedures for the Modern Burner Unit (MBU)

3-4.1 GENERATOR.

a. General. The purpose of the generator is to filter and vaporize the fuel when using leaded or unleaded fuel. Two (2) pounds of steel wool is packed inside the generator to accomplish the filtering of the fuel. To vaporize the fuel, the generator must be hot to convert the liquid fuel to a vapor and this is primarily done by the preheater, and after the burner is ignited the heat from the burner keeps the generator hot. The normal life expectancy of the generator, when using leaded fuel, is 450 to 500 hours. Due to carbon buildup and gasoline lead deposits replacement is required, usually during this time frame.

b. Removal. Refer to figure 3-1.

- (1) Make sure the unit is off and cool.

WARNING

Do not release pressure near any open flame or while unit is hot.

- (2) Loosen the fuel filler cap (1) to release air pressure.

- (3) Remove top shield by unhooking four springs (2) securing the shield (3) to the burner unit (4).

Remove the shield.

- (4) Remove flame valve knob (5) and place in holder (6).

- (5) Loosen nut (7) at rear of generator (8) and slide generator forward slightly and lift generator from burner.

- (6) Remove fuel feed tube (9) located under nut (7).

WARNING

Avoid breathing dust or fumes or placing generator to mouth. Never try to blow air through the generator to remove any matter. Dust and fumes could cause lead poisoning. Always bury an unserviceable generator if in combat and follow local policy during peacetime.

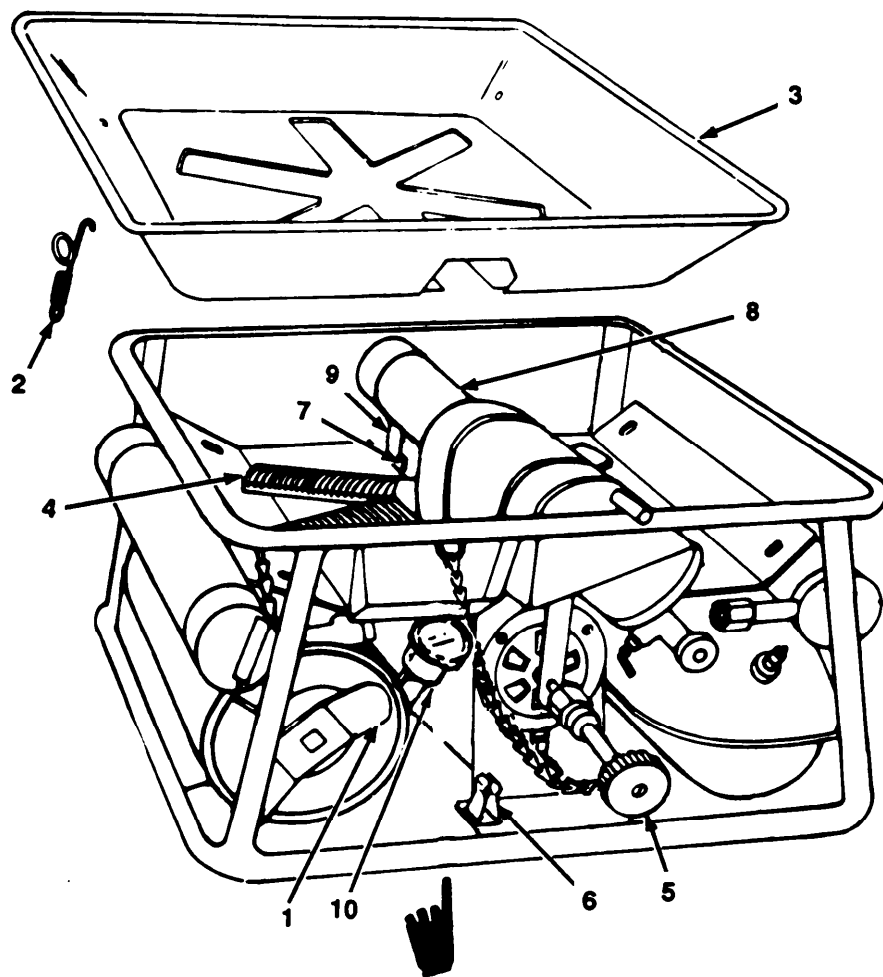

- | | |
|---------------------|------------------------|
| 1. Filler cap | 6. Holder |
| 2. Spring | 7. Nut |
| 3. Shield | 8. Generator |
| 4. Burner unit | 9. Feed tube |
| 5. Flame valve knob | 10. Air pressure gage. |

Figure 3-1. Generator Removal

c. *Cleaning.***WARNING**

Dry cleaning solvent, P-D-680 (Item 5, Table F-1), used to clean parts is potentially dangerous to personnel and property. Avoid repeated and prolonged skin contact. Do not use near open flame or excessive heat. Flash point of solvent is 100 degrees F to 138 degrees F (38 degrees C to 59 degrees C).

Avoid breathing dust or fumes or placing generator to mouth. Never try to blow air through the generator to remove any matter. Dust and fumes could cause lead poisoning. Always bury an unserviceable generator if in combat and follow local policy during peacetime.

- (1) Clean exterior of generator with a wire brush and/or cloth with cleaning solvent, P-D-680 (Item 5, Table F-1).
- (2) Clean fuel feeder tube (9) by rinsing in a solvent and replace immediately to eliminate loss or damage. Burner unit will fail to light if fuel feeder tube is lost, clogged or dented.

d. Repair. The only repair that can be done on the generator is repairing or repacking the generator flame valve assembly. Refer to figure 3-2.

- (1) Take apart the generator valve stem and wire brush it.
- (2) Coat valve stem threads and packing nut threads with anti-seize compound.
- (3) Replace packing as needed and reassemble valve.
- (4) Tighten packing nut until a slight bind is felt.

NOTE

Special care must be used when replacing orifice nut on generator. The valve stem should not protrude into orifice nut when replacing this nut.

- (5) Tighten orifice nut.
- (6) Close generator flame valve by turning flame valve knob clockwise (Item 5, Figure 3.1).

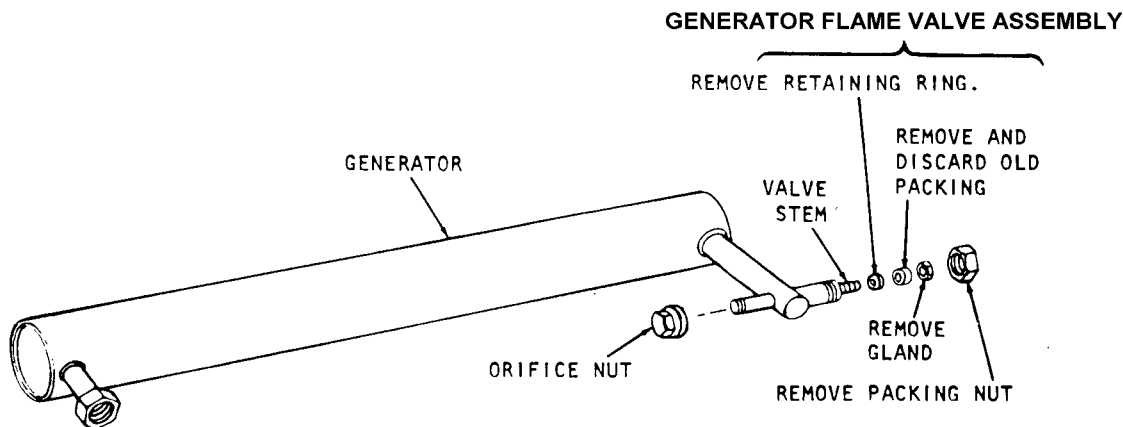

Figure 3-2. Packing the Generator Flame Valve.

WARNING

Improper packing of the generator valve assembly could result in injury to operating personnel

- (7). Check generator flame valve assembly for proper operation of the generator flame valve by turning the flame valve knob counterclockwise to open the valve. The knob should positively stop when completely opened. Any knob failing to positively stop when opened should be checked by tightening the packing nut or replace the packing

CHAPTER 4

ORGANIZATIONAL MAINTENANCE INSTRUCTIONS

Section I. GENERAL

4-1. SCOPE.

This chapter contains the removal, cleaning, inspection, and installation procedures for Organizational Maintenance.

Before maintenance always keep in mind the WARNINGS and CAUTIONS located on the inside front cover.

Section II. REPAIR PARTS, SPECIAL TOOLS, AND SUPPORT EQUIPMENT

4-2. COMMON TOOLS AND EQUIPMENT.

For authorized common tools and equipment refer to the Modified Table of Organization and Equipment (TMOE) applicable to your unit.

4-3. SPECIAL TOOL AND SUPPORT EQUIPMENT.

A special tool is required to remove and adjust the burner valves. Refer to Appendix B, Section III for description and tool number. There is no special support equipment required for maintenance of the field range outfit.

4-4. REPAIR PARTS.

Repair parts are listed and illustrated in Appendix C of this manual.

Section III. SERVICE UPON RECEIPT

4-5. GENERAL.

Refer to paragraph 2-5 for details of unloading, unpacking and reprocessing of the field range outfit prior to maintenance.

Section IV. PREVENTIVE MAINTENANCE CHECKS AND SERVICES

4-6. GENERAL.

a. This section contains information relative to organizational maintenance personnel in keeping the field range in a constant state of readiness. This is accomplished by performing preventive maintenance checks and services quarterly or every 250 hours of operation, whichever occurs first.

b. Table 4-1 contains a list of preventive maintenance checks and services which must be performed by organizational maintenance personnel.

(1) Item Number Column. Item numbers in the first column indicate the order in which things are to be done. The number in the item number column is used in the "TM Number" column on DA Form 2404, Equipment Inspection and Maintenance Worksheet, in recording results of PMCS.

(2) Item To Be Inspected Column. A general description of the item to be inspected. Used by maintenance personnel for orientation.

(3) Procedure Column. Procedure to be performed by maintenance personnel.

Table 4-1. Organizational Preventive Maintenance Checks and Services Quarterly Schedule

Item No.	Item to be Inspected	Procedures
1	Lid	<p style="text-align: center;">Cabinet Assembly</p> Inspect for improper closing, cracked or broken hinges, and defective brace or handle. Replace a defective lid. Inspect the lid hinge retainer and replace if necessary (para 4-8.1).
2	Lifting Handle	Check for breaks, binding, and loose or missing rivets. Replace a defective lifting handle (para 4-8.2).
3	Accessory Items	Inspect all accessory items for serviceability; repair or replace any unserviceable items.
4	Top and Bottom Shields	<p style="text-align: center;">Burner Assembly</p> Inspect for cracks, bends, and missing, or distorted springs. Repair or replace a damaged part (para 4-9.1).
5	Spare Generators	Inspect for dents and broken, loose or missing fittings. Check for leaks. Replace a defective spare generator (para 4-9.2).
6	Air Valve Assembly	Inspect for leaks and improper operation while pressurizing the unit. If valve leaks, shut unit down and replace air valve assembly (para 4-9.7).
7	Fuel Tank	Inspect for leaks from drain plug. If defective, replace. Check fuel tank for cracks, broken welds, damaged threads and other leaks. Replace a damaged fuel tank (para 4-9.6). Check fuel filler cap for cracks, damaged threads, defective gasket, and leaks. Replace a defective cap or gasket.
8	Preheater	Inspect preheater valve for leaks and improper operation. If valve leaks, shut down unit. Check for leaks between valve stem and packing nut. Tighten packing nut or repack valve as required. Replace a defective valve. Inspect the preheater head and shield for bends and breaks. Check the head for loose mounting. Inspect the orifice cleaning control for binding or improper operation. Inspect the preheater head bushing for damaged threads. Replace or repair the preheater (para 4-9.4).

Table 4-1. Organizational Preventive Maintenance Checks and Services Quarterly Schedule (Continued)

Item No.	Item to be Inspected	Procedures
Burner Assembly		
9	Main Generator	Inspect generator flame valve for leaks and improper operation. Check for leaks between valve stem and packing nut by using soapy solution. If valve leaks, tighten nut or repair valve (para 3-4.1). Check for improper operation by turning the flame valve knob counterclockwise to open the valve. The knob should positively stop when completely opened. Any knob failing to positively stop when fully opened should have the packing nut tightened or by replacing the packing (para 3-4.1). Inspect generator for carbon deposits, dents, breaks, and loose connections. Replace a defective generator (para 4-9.2).
10	Burner	Inspect for breaks, loose mounting, and clogged slots. During operation, check for erratic burning and blue or yellow flame. Replace a defective burner (para 4-9.3).
11	Air Pressure Gage	Inspect for breaks, broken glass, or bent needle. Check with tank filler cap removed to determine the gage reads zero. Then check after filling tank and closing tank filler cap, the gage will indicate a steady even increase in pressure as the tank is pressurized with the hand pump. If the gage will not pass above visual inspection and tests, the gage shall be replaced (para 4-9.5).
12	Air Control Shutter and Mixing Chamber	Inspect shutter for binding, loose mounting and damaged control lever. Tighten mounting hardware. Inspect mixing chamber for cracks. Replace any defective parts (para. 4-9.3). <div style="text-align: center; border: 1px solid black; padding: 2px; width: fit-content; margin: 10px auto;">WARNING</div> Use extreme care when utilizing the air compressor to pressurize the fuel tank.
13	Safety Valve Device	Inspect device for improper operation, leaks, loose hardware for bent tubing. Safety system for proper functioning. DRAIN FUEL TANK. Using air compressor, pressurize tank to approximately 60 (PSIG) where the safety valve should operate. After the safety opens, pressure should drop rapidly to approximately 35 ± 10 PSIG at which point the safety valve should close. Using soapy solution, check for leaks. Set burner unit on end and turn fuel filler cap slowly counterclockwise to release air pressure. Tighten any loose hardware. Replace defective device (para 4-9.10).

Section V. TROUBLESHOOTING

4-7. GENERAL.

This section provides information useful to organizational maintenance personnel in diagnosing and correcting unsatisfactory operation or failure of the field range outfit.

4-7.1 TROUBLESHOOTING.

Refer to table 4-2 for a listing of the possible malfunctions that may occur in the field range outfit.

TABLE 4-2. TROUBLESHOOTING

MALFUNCTION	TEST OR INSPECTION	CORRECTIVE ACTION
1. FUEL SYSTEM FAILS TO MAINTAIN PRESSURE.		
Step 1. Fuel filler LEAKS		Remove filler cap and replace gasket.
Step 2. Air valve assembly defective.		Replace air valve.
Step 3. Fuel tank defective.		Replace fuel tank
Step 4. Safety valve does not reseal.		Replace safety valve device.
2. PREHEATER FAILS TO IGNITE.		
Step 1. Preheater fuel feed tube assembly is damaged or missing.		Repair or replace fuel feed tube assembly.
Step 2. Preheater generator defective.		Replace preheater generator.
3. BURNER FAILS TO IGNITE.		
Step 1. Preheater generator defective.		Replace preheater generator.
Step 2. Generator is defective.		Replace generator.
Step 3. Feed tube assembly missing, clogged or dented.		Shut down-allow to cool-clean feed tube assembly or have replaced.
4. YELLOW BURNER FLAME.		
Step 1. Generator flame valve is defective.		Repack or replace valve.
Step 2. Generator is defective.		Replace generator.
5. BURNER FLAME TOO LOW.		
Step 1. Generator defective.		Replace generator.
Step 2. Generator flame valve is defective.		Repack or replace valve.
6. FUEL LEAKS AT GENERATOR VALVE.		
		Valve or valve packing is defective. Repack or replace valve.
7. FUEL LEAKS AT PREHEATER VALVE.		
		Valve or valve packing is defective. Repack or replace valve.

TABLE 4-2, TROUBLESHOOTING - Continued

MALFUNCTION	TEST OR INSPECTION	CORRECTIVE ACTION
8. PRESSURE RISES ABOVE SAFE LIMIT ON AIR PRESSURE GAGE.		

- Step 1.** Fuel tank too full.
Fill with only 8 quarts (7.6 liters) of gasoline.
- Step 2.** Air pressure gage is defective.
Replace gage.

Section VI. MAINTENANCE PROCEDURES

4-8. CABINET.

This section contains the maintenance instruction for the cabinet. It includes the lid lifting handles and latches, and cradle.

4-8.1 LID ASSEMBLY.

a. General. The lid is attached to the top of the cabinet by lid hinges. The whole lid assembly is fastened to the cabinet by two wing nuts that screw into the lid hinge.

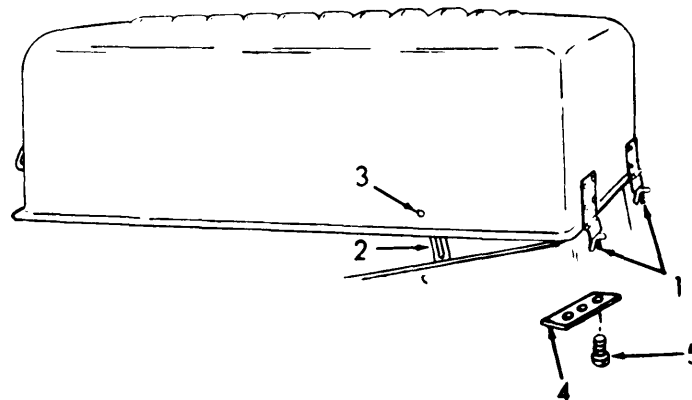

b. Removal.

- (1) Loosen the two wing nuts (1).
- (2) Align the lid brace (2) with its retaining pin (3) so that the brace can be slipped over the head of the lid retaining pin.
- (3) Lift the lid off of the cabinet.
- (4) To remove the hinge retainers (4), remove the screws (5) securing them to the cabinet. The retainers and wing nuts come apart when the screws are removed.

c. Replacement.

- (1) If the wing nuts have been removed, insert them into their matching holes on the cabinet. Slide the lid hinge retainers (4) over the wing nuts (1) and align holes in retainers with the holes in the cabinet. Insert mounting screws (4) and tighten.
- (2) Align holes in lid hinge with wing nuts (1) and tighten nuts.
- (3) Fit lid retainer pin head (3) into lid brace (2) and lower lid.

4-8.2 LIFTING HANDLES AND LATCHES.

a. *General.* The lifting handles are attached to two brackets that are riveted to the sides of the cabinet.

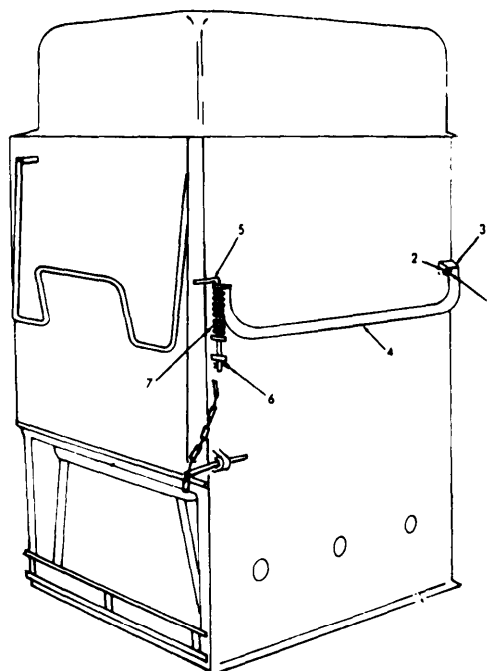

b. *Removal.*

- (1) Remove the cotter pin (1).
- (2) Remove the pin (2) securing the handle to the bracket (3) and remove the handle (4).
- (3) To remove the right lifting handle, it will be necessary to first remove the upper latching pin (5).
- (4) Remove the upper latching pin (5) by removing the cotter pin (6) and washer that secures the latching pin spring (7) and latching pin.

c. *Replacement.*

- (1) Place the left lifting handle in its brackets and replace the pins, securing them with new cotter pins.
- (2) Place the right lifting handle in its brackets and replace the pins, securing them with cotter pins.
- (3) Replace the upper latching pin and spring.

4-8.3 CRADLE.

a. *General* The cradle is used to support the 10 and 15 gallon cooking pots in the field range.

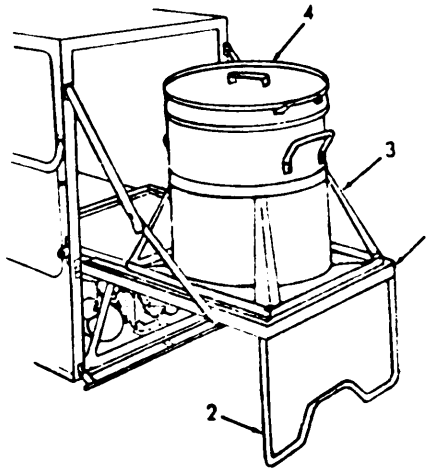

b. Removal.

- (1) Lower the door (1) so that it sits on the door rest (2).
- (2) Slide the cradle (3) forward onto the field range door (1), so that the pot (4) can be removed.
- (3) Remove the cradle (3) by lifting.

c. Replacement.

- (1) Place the cradle (3) on the door (1).
- (2) Insert pot (4).
- (3) Slide pot and cradle into field range.
- (4) Raise door (1) and fold door rest (2) against door.

4-9. BURNER UNIT.

This section contains the organizational maintenance instructions for the burner unit. It includes the burner, generator, preheater, fuel tank, and associated components.

Special tools. Combination wrench used for removal and adjustment of burner valves (See Fig D-8).

4-9.1 TOP SHIELD.

a. General. The primary purpose of the top shield is to reflect the heat upward and away from the fuel tank to help prevent pressure buildup. The top shield is secured to the frame of the burner unit by four (4) hook springs. The shield has cutouts, allowing the generator and burner to protrude.

WARNING

Do not operate burner without top shield (2).

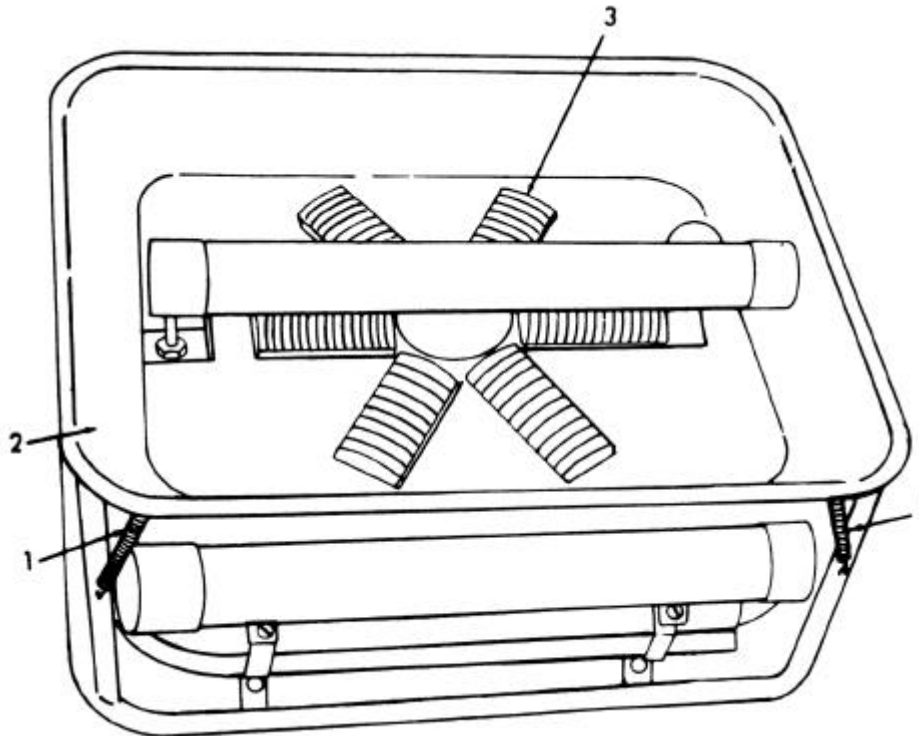

b. Removal.

- (1) Unhook four springs (1) securing the top shield (2) to the burner unit (3).
- (2) Remove top shield (2).

c. Cleaning. The top shield is provided with a protective coating. No abrasive compound or material can be used. Wash in hot soapy water. Rinse in clean boiling water and wipe dry.

d. Replacement. To replace, fit shield over generator and burner units, and hook springs into the holes in shield.

4-9.2 GENERATOR.

a. General. This paragraph provides the replacement procedures for the generator. Refer to paragraph 3-4.1 for removal, cleaning and repair procedures.

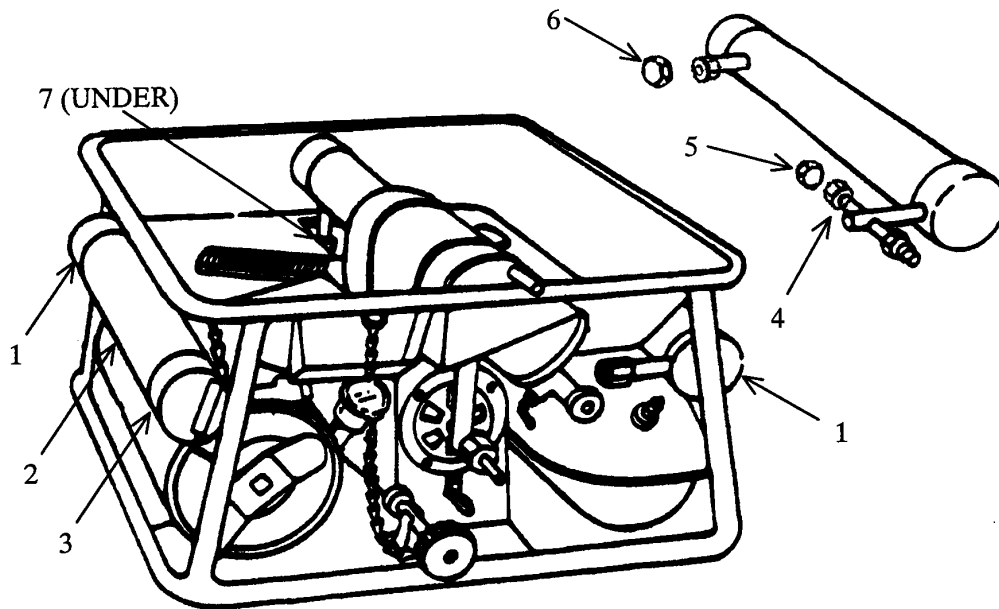

b. Replacement. Replace bad generator with one of the two sparegenerators (1) attached to the unit.

(1) Remove the two screws (2) and (3) that attach the spare generator (1) to the burner unit.

NOTE

Replace screws to secure generator brackets to prevent damage to bracket during handling of burner unit, and until a new spare generator is received.

(2) Remove spare generator (1). Remove plastic orifice protective cap (5) and plastic inlet protector plug (6) if not previously removed.

NOTE

The plastic shipping caps and plugs should be removed from the spare generator assemblies when they are installed on the Burner Unit. This will eliminate melting of the plastic caps and plugs during burner operation.

(3) Check that fuel orifice nut (4) is installed and tight on generator tube. Insert orifice end of generator into mixing chamber opening and slide generator to the rear until orifice and mixing chamber mesh.

(4) Insert generator inlet into fuel feed tube (7) and tighten nut.

4-9.3 BURNER, FUEL FEEDER TUBE, BOTTOM SHIELD, AND MIXING CHAMBER AND AIR SHUTTER ASSEMBLY.

a. General. The purpose of the burner is to evenly distribute the flame. Fuel vapors pass through the mixing chamber and out the burner slots and the vapor is ignited. The slots must be clean and free of any foreign matter. The bottom shield helps to deflect the heat from the fuel tanks.

b. Preliminary Requirements.

(1) Remove top shield (para 4-9.1.)

(2) Remove generator and clean and replace fuel feed tube (para 4-9.2).

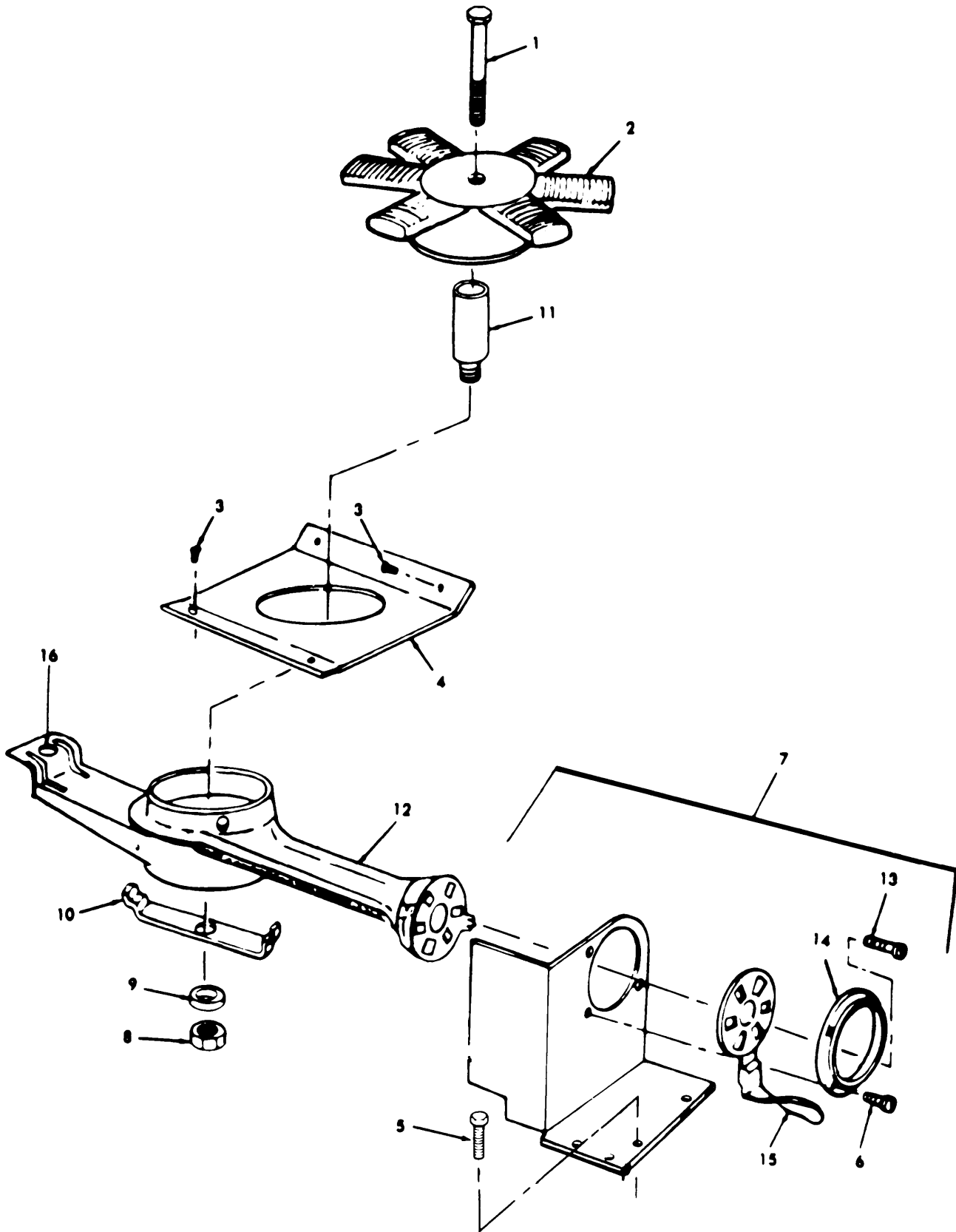

c. Removal

- (1) Remove bolt (1) from burner (2), and remove burner.
- (2) Remove four screws (3) that attach the bottom shield (4) to the spare generator brackets. Remove bottom shield.
- (3) Remove two screws (5) that attach mixing chamber and shutter assembly (7) to frame. Lift assembly (7) from frame.
- (4) Remove nut (8), washer (9), holder (10), if equipped, and remove bushing (11) from mixing chamber (12).
- (5) Remove four screws (6) and (13) that attach retaining ring (14) and air shutter (15) to mixing chamber (12). Remove air shutter and retaining ring. Remove flame valve knob from valve knob holder.
- (6) Remove mixing chamber (12) by lifting straight up from fuel tank.

WARNING

Dry cleaning solvent, P-D-680 (item 5, Table F-1), used to clean parts is potentially dangerous to personnel and property. Avoid repeated and prolonged skin contact. Do not use near open flame or excessive heat. Flash point of solvent is 100 degrees F to 138 degrees F (38 degrees C to 59 degrees C).

d. Cleaning.

- (1) The burner is cleaned with a wire brush and slot cleaner (figure 2-3, item 8). Use the slot cleaner in a rocking motion to prevent possible damage to the slot, clean each slot carefully to remove all carbon or foreign matter. Wash burner with hot soapy water, rinse with clean boiling water and air dry. The bottom shield is cleaned in the same manner as the top shield. Clean the mixing chamber and air shutter assembly in cleaning solvent P-D-680 (item 5, Table F-1), and wipe dry.
- (2) Lubricate air shutter after cleaning.
- (3) Coat the burner and unpainted parts with P-10, Grade 1, Preservative Oil (item 6, Table F-1). If the mixing chamber needs painting, use aluminum paint only (item 7, Table F-1).

e. Reassembly,

- (1) Replace mixing chamber (12).
- (2) Replace air shutter (15) and retaining ring (14) using screws (6) and (13).
- (3) Place bushing (11) in mixing chamber (12). Install holder (10), if equipped, using washer (9) and nut (8).
- (4) Place mixing chamber and air shutter assembly (7) into frame and replace screws (5). Do not tighten screws (5) at this time.
- (5) Place bottom shield (4) on spare generator brackets and tighten screws (3).
- (6) Replace burner (2).

NOTE

Position the burner so that the long arm is facing toward the air shutter (front of burner). This will be directly under the generator when it is installed.

- (7) Apply a light coat of antiseize compound to threads of bolt (1) and replace bolt.

CAUTION

Overtightening bolt will cause damage to the mixing chamber.

- (8) Replace generator (para 4-9.2).

NOTE

Position mixing chamber and air shutter assembly (7) so that the generator packing nut is flush with air shutter assembly opening.

- (9) Tighten screws (5).
- (10) Replace top shield (para 4-9.1).
- (11) Install flame valve knob in flame valve knob holder.

4-9.4 PREHEATER ASSEMBLY.

a. Preliminary Requirements.

- (1) Remove top shield (para 4-9.1).
- (2) Remove generator (para 4-9.2).

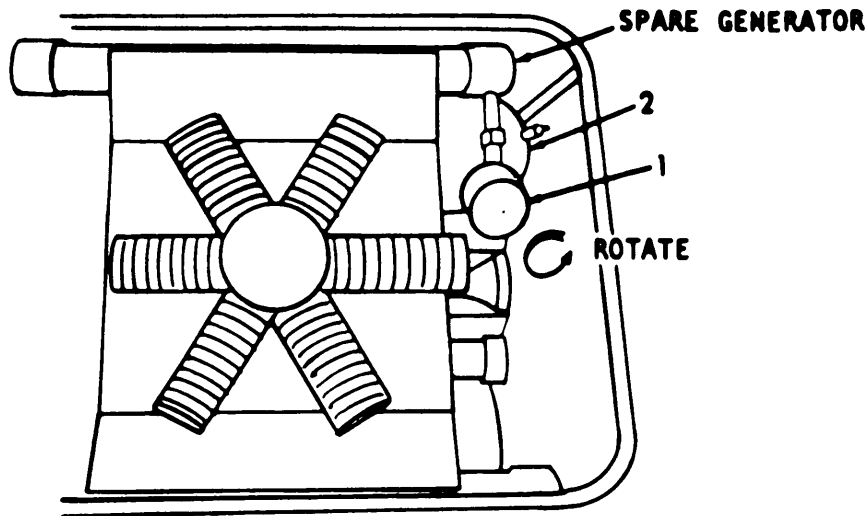

b. Removal.

- (1) Loosen spare generator strap screws and rotate spare generator away from burner body.
- (2) Remove preheater assembly (1) by rotating counterclockwise until it is removed from fuel tank (2).

c. Disassembly. Refer to figure 4-1 and disassemble the preheater assembly to the extent necessary to make repairs. Disassemble in numerical sequence.

d. Repair. In addition to replacing defective components of the preheater assembly, the preheater valve may require packing. Refer to figure 4-2 to pack the preheater valve.

e. Reassembly. Depending upon the amount of disassembly, the preheater may be reassembled in the reverse order.

CAUTION

Do not overtighten the preheater assembly.

- f. Replacement.* Replace the preheater. Turn the preheater clockwise to tighten.

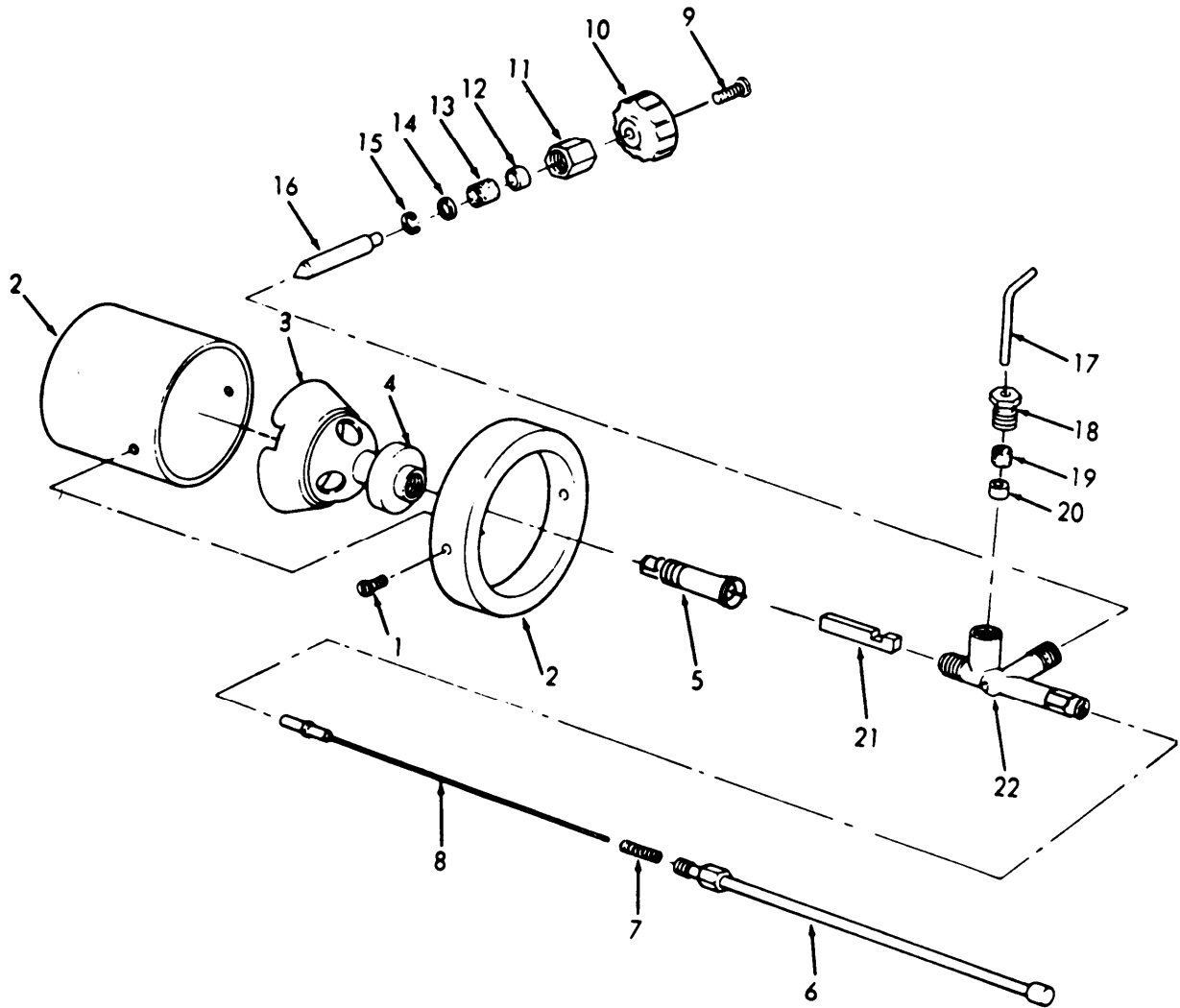

- | | |
|----------------------|-------------------|
| 1. Screw | 12. Packing gland |
| 2. Drip cup assembly | 13. Packing |
| 3. Preheater head | 14. Ring |
| 4. Fuel cup | 15. Ring |
| 5. Generator | 16. Stem |
| 6. Feed | 17. Handle |
| 7. Spring | 18. Nut |
| 8. Needle | 19. Packing |
| 9. Screw | 20. Packing valve |
| 10. Knob | 21. Block |
| 11. Nut | 22. Body |

Figure 4-1. Preheater Assembly, Exploded View.

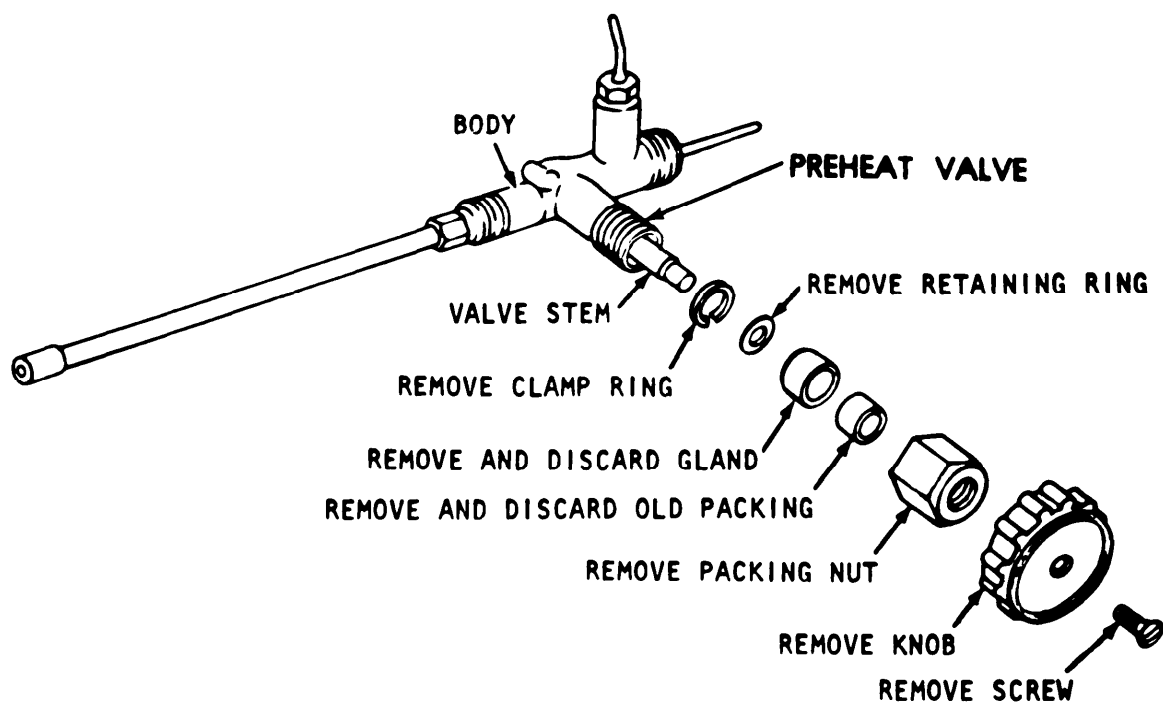

NOTE

After repacking, inspect for leaks between packing nut and valve stem. Tighten packing nut as required. Apply anti-seize compound to threads of preheater valve.

Figure 4-2. Packing the Preheater Valve.

4-9.5 AIR PRESSURE GAGE.

a. Preliminary Requirements. Remove the top shield (para 4-9.1).

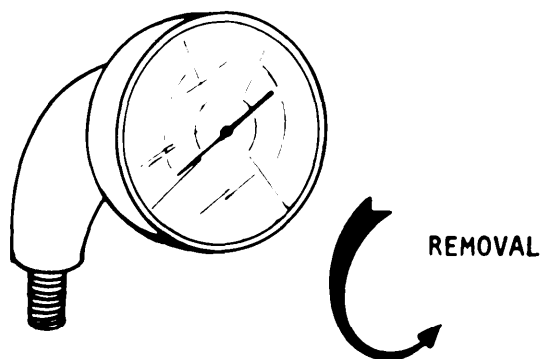

b. Removal. Remove the air pressure gage by turning counterclockwise.

c. **Replacement**

- (1) Replace air gage by turning clockwise until tight.
- (2) Pressurize the system (para 2-6) and check for leaks.

NOTE

A soap and water solution can be applied to fuel system fittings to check for leaks.

- (3) Replace the top shield (para 4-9.1).

4-9.6 FUEL TANK

a. *Preliminary Requirements.*

- (1) Remove top shield (para 4-9.1).
- (2) Remove generator (para 4-9.2).
- (3) Remove spare generator (para 4-9.2).
- (4) Remove burner, bottom shield, mixing chamber and air shutter assembly (para 4-9.3).
- (5) Remove preheater assembly (para 4-9.4).
- (6) Remove pressure gage (para 4-9.5).
- (7) Remove safety valve device (para 4-9.10).

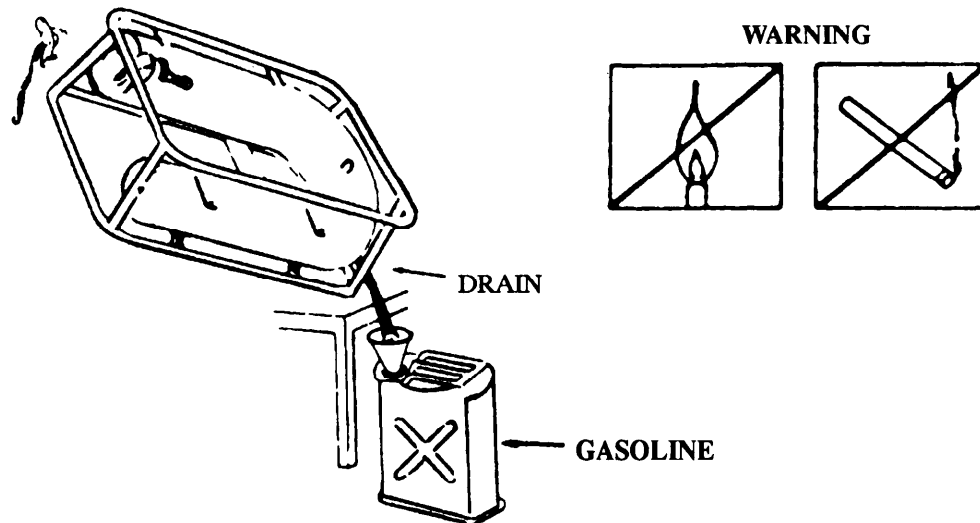

Do not drain fuel while smoking or near an open flame or injury may result.

- (8) Drain fuel tank by removing drain plug and standing tank with drain down and slightly tipped to allow fuel to drain out of tank. Drain into an approved container. During draining of fuel, remove filler cap on U-Tank.

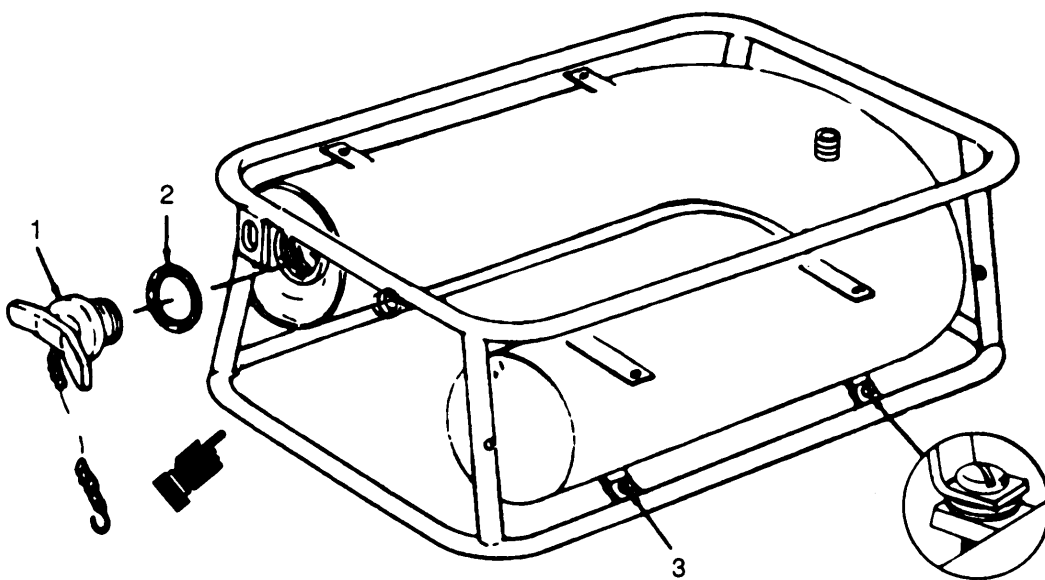

NOTE

Check bottom of burner fuel tank for signs of dragging or bumping of the base bar. If required, shim under the fuel tank brackets with 1/4 inch flat washers (NSN 5310-00-639-7554) to raise the fuel tank's position within the burner frame. After raising fuel tank if required, check generator alignment as follows:

- (9) Loosen fittings on both ends of generator.
- (10) Add flat washers as required under air shutter bracket to obtain proper alignment.

b. Removal

- (1) Remove fuel tank cap (1) and gasket (2).
- (2) Remove four screws (3) that attach fuel tank to frame.
- (3) Remove fittings and safety valve device from U-Tank.

c. Cleaning.



Dry cleaning solvent, P-D-680 (item 5, Table F-1), used to clean parts is potentially dangerous to personnel and property. Avoid repeated and prolonged skin contact. Do not use near open flame or excessive heat. Flash point of solvent is 100 degrees F to 138 degrees F (38 degrees C to 59 degrees C).

- (1) Clean the inside of the fuel tank with cleaning solvent, PD-680 (item 5, Table F-1).
- (2) Drain fuel tank and keep it dry.

d. Replacement

Repeat the removal procedure in reverse sequence. Replace the drain plug gasket or filler cap gasket if damaged.

4-9.7 AIR VALVE ASSEMBLY.

- a. **General.** The air valve cap forms an air tight seal for the air valve and also protects the air valve threads. The Air Valve Assembly consists of a check valve, air filler valve, and cap. The Air Valve Assembly is a one way valve system allowing air to pass into the gas tank and preventing it from escaping.



- b. **Removal.** Rotate air valve assembly counterclockwise and remove from fuel tank.
 c. **Replacement.** The air valve assembly can be replaced by reversing the above procedure. Apply anti-seize compound to threads of air valve before installation.

4-9.8 FILLER CAP ASSEMBLY.

- a. **General.** The filler cap assembly provides a tight seal for the fuel tank. The cap is also used to release the pressurized air inside the tank.

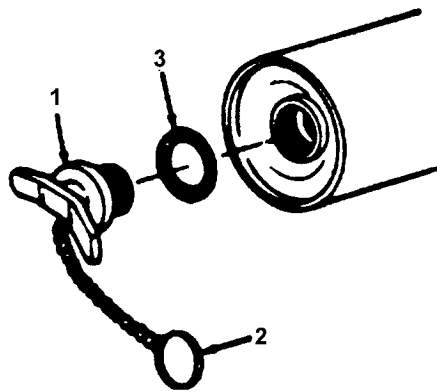

- b. **Removal.**
- (1) Unscrew the filler cap (1) slowly to release air pressure.
 - (2) Remove key ring (2) from frame.
- c. **Replacement.**
- (1) Replace key ring (2), gasket (3) or filler cap (1) as required.
 - (2) Reassemble and replace filler cap.

4-9.9 FRAME.

If the frame requires replacement, all disassembly procedures in paragraph 4-9.1 through 4-9.6 must be accomplished.

4-9.10 SAFETY VALVE DEVICE.

a. General. The safety valve device is designed to release if fuel tank air pressure exceeds approximately 60 psig. It will reset at approximately 35 ± 10 psig.

b. Removal.

- (1) Remove top shield (para 4-9.1).
- (2) Remove generator assembly (para 4-9.2).
- (3) Remove burner, fuel feeder tube, and bottom shield (para 4-9.3).
- (4) Remove air pressure gage (1).
- (5) Remove locking nut (2).
- (6) Loosen and remove adapter (3) from fuel tank assembly.
- (7) Remove safety valve device.

c. Replacement. Reverse removal procedures.

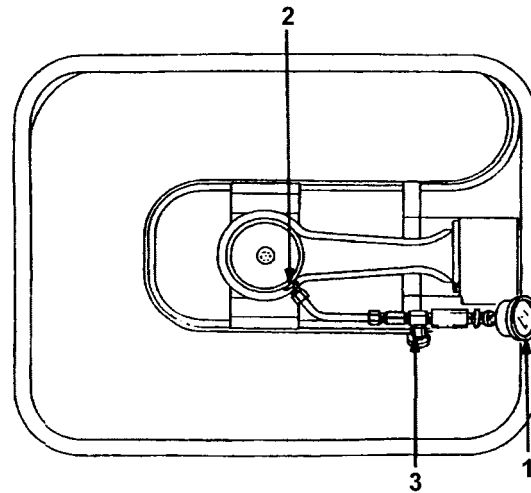

NOTE

The safety valve device is stocked only in kit form. If the device is being installed on existing units, follow procedures outlined above.

4-9.11 SAFETY VALVE DEVICE KIT INSTALLATION. (Refer to Figure 4-3)

- a.* Present production M2 Burner Units have a safety valve device installed during manufacture.
- b.* The safety valve device is an assembly stocked only in kit form, which is connected between the U Tank and the mixing chamber.

WARNING

A safety valve device should be installed on all M2 and M2A burner units as an added safety feature.

- c.* Instructions for installation and testing, which are packaged in each kit are as follows:
 - (1) Release pressure from tank and drain fuel tank (para 4-9.6 and 4-9.8).
 - (2) Remove top shield, generator, burner, and bottom shield (para 4-9.1 and 4-9.3).
 - (3) Place unit in the horizontal position and remove mixing chamber (para 4-9.3).

- (4) Cut out attached template figure 4-4 (or template furnished with safety system kit) and bend tabs as shown.
- (5) Place template over top of mixing chamber and secure with tape. Using tap, punch mark to location of the hole to be drilled in the side of the mixing chamber. Drill a 3/16" diameter hole at the marked location to be used as a pilot hole: then with a 1/2" diameter drill, complete drilling the hole. (Remove burrs with a file.)
- (6) Remove pressure gage and 1/8" street elbow. (para. 4-9.5)
- (7) Dissassemble tubing from safety system assembly.
- (8) Assemble safety valve into branch tee into adapter where street elbow was removed. Add nipple and 45° elbow into open end of the branch tee fitting (see Figure 4-3). Add Permatex to air pressure gage threads.
- (9) Reassemble gage into 45° elbow fitting.
- (10) Reinstall mixing chamber. (para. 4-9.3).
- (11) Reattach tubing to safety valve and, using bulkhead nuts, secure the tubing into the drilled hole in the mixing chamber.
- (12) Reattach the generator. (para 4-9.2).

WARNING

Use extreme care when utilizing the air compressor to pressurize the fuel tank.

- (13) Test safety system for proper functioning by pressurizing the tank, using air compressor to approximately 60 ± 5 psig where safety valve should operate. After safety valve opens, pressure should drop rapidly to approximately 35 ± 10 psig at which point safety valve should close. Using soapy solution check for leaks.
- (14) Set burner unit on end and release air pressure. (para. 4-9.8).
- (15) Remove the generator. (para. 4-9.2)
- (16) Reinstall bottom shield, burner generator, and top shield (paras. 4-9.3, 4-9.2, and 4-9.1)

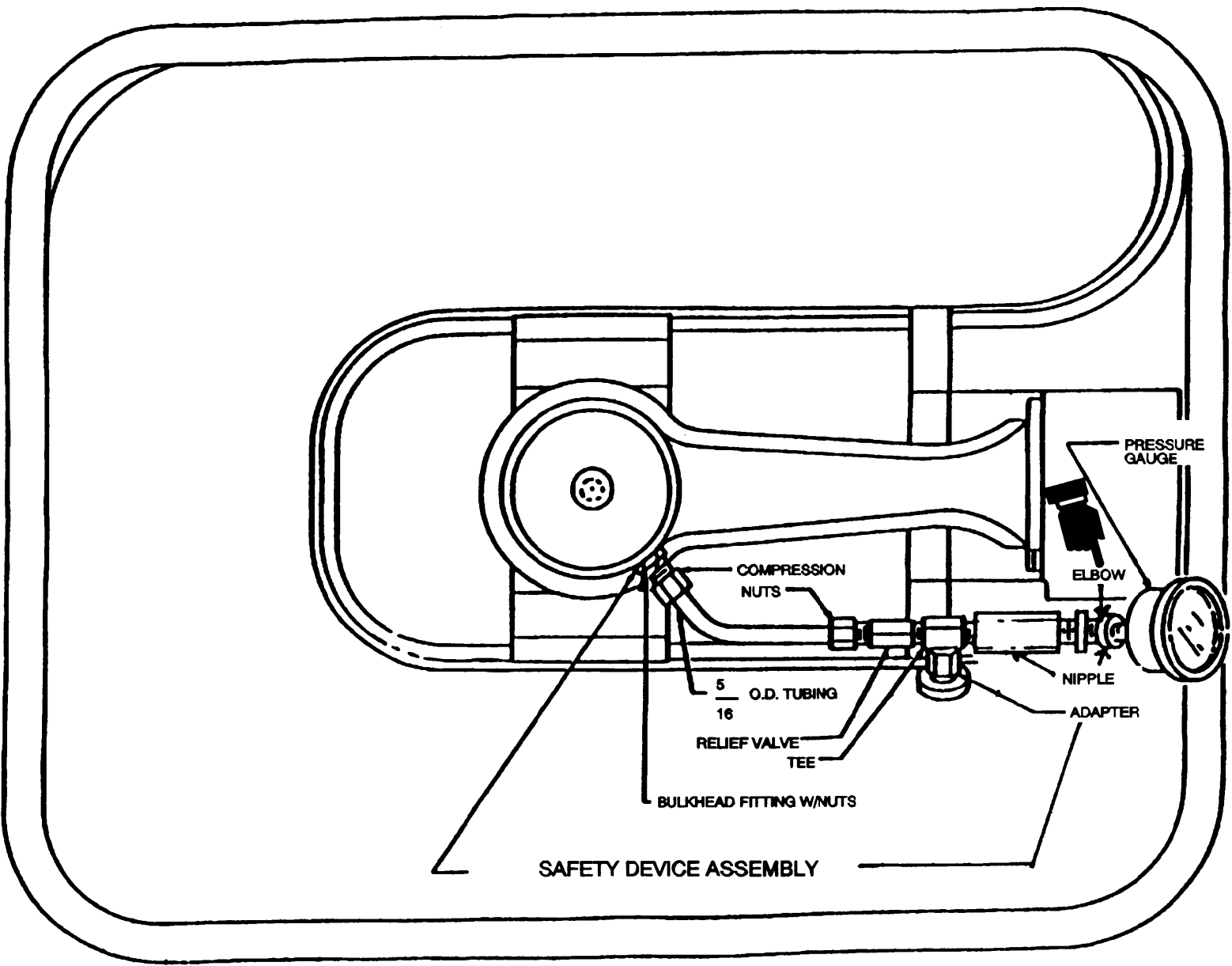

Figure 4-3 Safety Device Assembly

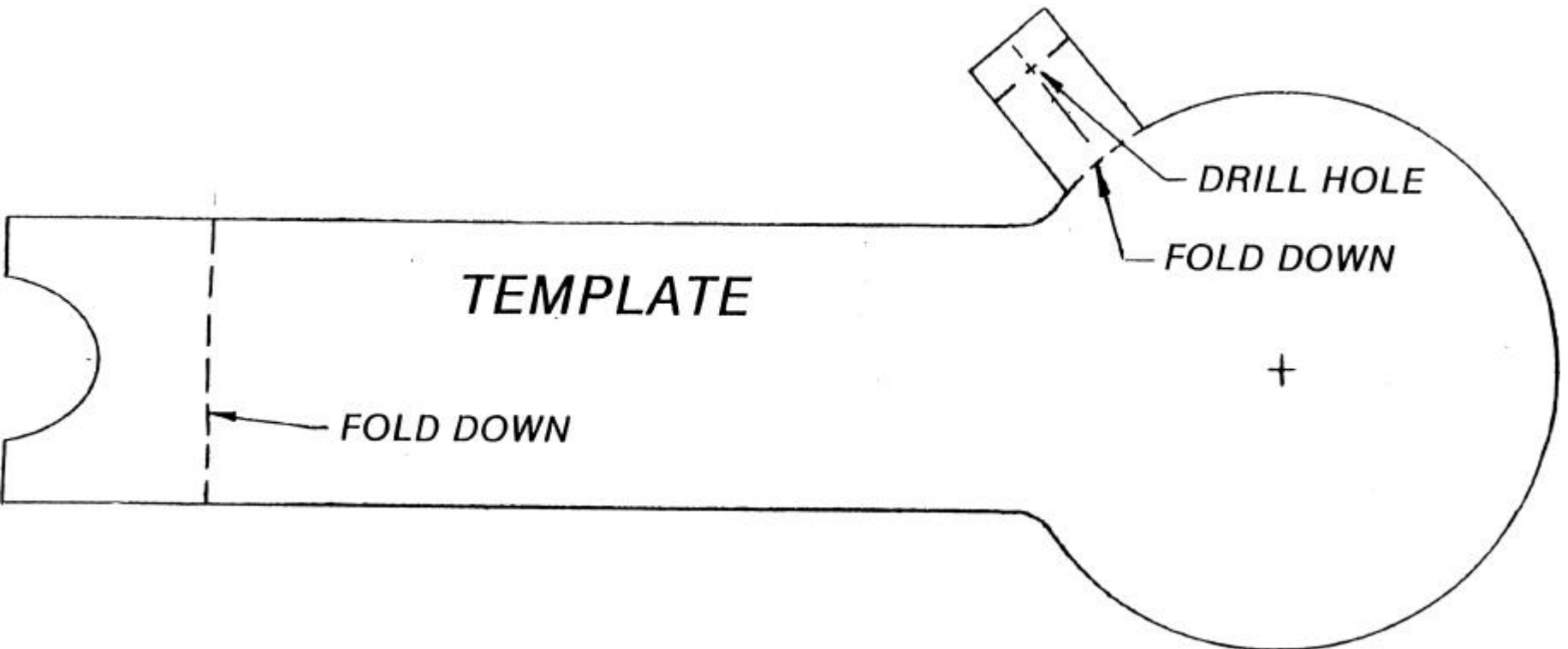

Figure 4-4. Safety System Template

Change II

4-18.3/(4-18.4 blank)

Section IV. SERVICE BEFORE STORAGE

4-10. GENERAL.

This section contains the instructions required to service the field range outfit prior to storage.

4-10.1. BURNER UNIT.

- a. Remove grease, caked carbon, and cooking oil from the burner unit (including flanges and threads) by wire brushing.
- b. Clean burner slots with burner slot cleaner.
- c. Wash fire unit with hot soapy water and rinse with clear water.

WARNING

Dry cleaning solvent, P-D-680 (item 5, Table F-1), used to clean parts, is potentially dangerous to personnel and property. Avoid repeated and prolonged skin contact. Do not use near open flame or excessive heat. Flash point of solvent is 100 degrees F to 138 degrees F (38 degrees C to 59 degrees C).

- d. Take apart the generator valve stem, wire brush and coat valve stem threads and packing nut threads with antiseize compound. Valve stem should be unscrewed before replacing nut orifice. Replace packing as needed and reassemble valve.
- e. Place dry cleaning solution P-D-680 (item 5, Table F-1) in fuel tank. Agitate, then drain fuel tank by removing drain plug in rear of U-tank. Reinstall and tighten drain plug. Hand tighten fuel filler cap. Close Flame Valve and Preheater Valve. Keep the tank dry.
- f. Coat the burner and unpainted parts with P-10 Grade 1 Preservative Oil (item 6, Table F-1).
- g. If the mixing chamber or the outside of the fuel tank needs painting, use aluminum paint only (item 7, Table F-1).
- h. Check bottom of fuel tank for signs of dragging or bumping of the base bar. If required shim under the tank brackets with ¼ inch flat washers for adequate clearance between base bar and tank.

4-10.2. CABINET.

- a. Clean Cabinet with hot soapy water and rinse with clear water or approved solvent. If available, a commercial type nylon cleaning pad may be used to remove corrosion or caked-on grease.

CAUTION

DO NOT use abrasive cleaners or wire brushes.

- b. Check cabinet for signs of corroding or peeling. The coating over the metal may show spots. If so, remove them with soap and water, an approved solvent, or nylon cleaning pad.
- c. Check braces, angles and support parts for proper fastening.
- d. Check latch pins, shutters, door latches and rests, lift handles, and inner rack parts for proper operation.
- e. Use a wooden match or toothpick to clean bracket joints, spring and pin assemblies, and rivet seats.
- f. Deleted.
- g. Deleted.

4-10.3 UTENSILS.

- a.* Clean with hot soapy water and rinse with clean water. Scouring will destroy the finish.
- b.* All items are to be coated with corrosion preventive compound P14 (item 1, Table F-1).
- c.* Wrap each utensil with barrier material (item 3, Table F-1).

Section VII. STORAGE AFTER PREPARATION FOR STORAGE

4-11 GENERAL.

- a.* Store the field range outfit in a building, shed, or under cover.
- b.* If the field range outfit is to be stored outside, place on a pallet or planking. Place a canvas tarp or waterproof cover over it.
- c.* Be sure the storage location is firm, level, and well drained.

CHAPTER 5

DIRECT SUPPORT MAINTENANCE INSTRUCTIONS

Section I. GENERAL

5-1. GENERAL.

This chapter contains the removal, inspection, and installation procedures for Direct Support Maintenance.

Before maintenance always keep in mind the WARNINGS and CAUTIONS located on the inside front cover.

Section II. CABINET

5-2. GENERAL.

- a. This section contains the maintenance instructions for the cabinet. It includes lid hardware, door, and cabinet hardware. Refer to Figure 5-1.
- b. The repairs required in most cases will require welding or replacing components that are riveted to the unit. Refer to TM 9-450 for information on metal body repairs.

5-2.1 LID HARDWARE.

- a. BRACE (Figure 5-1, item 27) is attached by pins (21 and 25) and washers (26).
- b. HINGE (Figure 5-1, item 20) is attached by rivet (19).
- c. HANDLE (Figure 5-1, item 24) and retainer (23) is attached with rivet (22).

5-2.2 DOOR HARDWARE.

- a. HINGE (Figure 5-1, item 11) is held in place with bracket (6) and rivet (5).
- b. LATCH (Figure 5-1, item 4) is inserted in bracket (2) and riveted (1) to wear plate (3).
- c. SLIDE CRADLE (Figure 5-1, item 16) is attached with rivet (15).
- d. SHUTTER (Figure 5-1, item 9) moves on slides (8) which are attached by rivet (45).
- e. DOOR BRACKET (Figure 5-1, item 2) and wear plate (3) are held in place with rivets (1),
- f. HINGE BAR (Figure 5-1, item 11) is held in place by bracket (13) and rivet (12).

5-2.3 CABINET HARDWARE.

- a. LATCH PIN (Figure 5-1, item 37) is attached with rivet (36).
- b. CONNECTOR (Figure 5-1, item 43) is attached with rivet (42).
- c. LIFTING HANDLE BRACKET (Figure 5-1, item 45) is attached with rivet (44). Handle (32), must be removed by removing cotter pin (30) and pin (31) prior to removal of bracket.
- d. BAR, FIRE UNIT RETAINER (Figure 5-1, item 14) is held in place with hinge bracket (6) and is attached with rivet (5).

NOTE

Items in Figure 5-1 that are not explained above are for information.

All data on page 5-2 has been deleted.

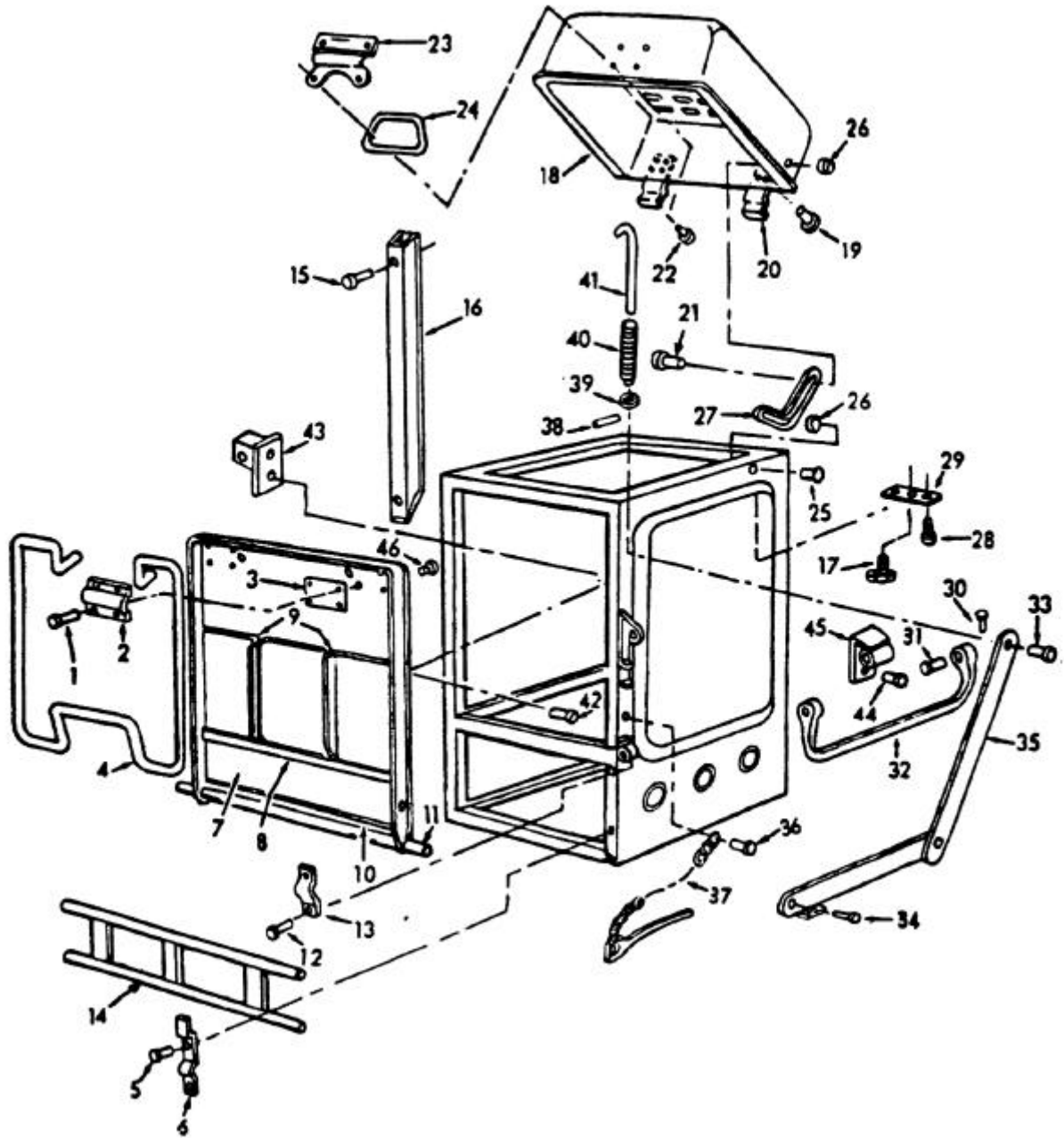

- | | | | | |
|-----------------|-------------|-------------|-----------------|--------------|
| 1 Rivet | 11 Hinge | 21 Pin | 31 Pin | 41 Pin |
| 2 Bracket | 12 Rivet | 22 Rivet | 32 Handle | 42 Rivet |
| 3 Plate | 13 Hanger | 23 Retainer | 33 Rivet | 43 Connector |
| 4 Latch | 14 Bar | 24 Handle | 34 Rivet | 44 Rivet |
| 5 Rivet | 15 Rivet | 25 Pin | 35 Stay | 45 Bracket |
| 6 Hinge Bracket | 16 Slide | 26 Washer | 36 Rivet | 46 Rivet |
| 7 Door | 17 Wing nut | 27 Brace | 37 Latching pin | |
| 8 Slide | 18 Lid | 28 Screw | 38 Pin | |
| 9 Shutter | 19 Rivet | 29 Retainer | 39 Washer | |
| 10 Bracket | 20 Hinge | 30 Pin | 40 Spring | |

Figure 5.1. Cabinet Assembly, Exploded View.

APPENDIX A

REFERENCES

A-1. FIRE PROTECTION AND SAFETY

TB 5-4200-200-10 Hand Portable Fire Extinguishers Approved for Army Users

A-2. LUBRICATION

C9100IL Fuels, Lubricants, Oils, and Waxes

A-3. MAINTENANCE

*MIL-R-14601 Range and Accessory Outfits, Field, Gasoline
 *MIL-B-121 Barrier Material, Greaseproofed, Waterproofed, Flexible
 *MIL-B-40098 Burner Unit, Gasoline, Field Range Outfit, M2A
 *MIL-C-10382 Corrosion Preventive, Petrolatum, Spraying Application for
 Food Handling Machinery and Equipment
 TM 5-640 Ranges, Bake Ovens and Burners for Mess Equipment,
 Repairs and Utilities
 TM 5-641 Inspections and Preventive Maintenance Services, Ranges,
 Bake Ovens and Burners for Other Mess Equipment
 TM 43-0139 Painting Instructions for Field Use
 TM 38-750 The Army Maintenance Management System
 SC 7360-90-CL-N03 Accessory Outfit, Gasoline Field Range
 SC 7360-90-CL-N02 Range Outfit, Field, Gasoline

A-4. SHIPMENT AND STORAGE

*MIL-STD-129 Military Marking
 TM 38-230-2 Preservation, Packaging, and Packing of Military Supplies
 and Equipment (Packing)
 TM 740-90-1 Administrative Storage of Equipment

A-5. DEMOLITION

TM 750-244-3 Destruction of Equipment to Prevent Enemy Use

* For reference only

APPENDIX B MAINTENANCE ALLOCATION CHART

Section I. INTRODUCTION

B-1. MAINTENANCE ALLOCATION CHART (MAC)

a. General. This MAC assigns maintenance functions in accordance with the Three Level Maintenance concept. The three levels are depicted on the MAC as:

UNIT level—corresponds to an O code in the Repair Parts and Special Tools List (RPSTL). A C code entry under UNIT denotes maintenance performed by the crew or operator within UNIT maintenance.

INTERMEDIATE level—corresponds to an For an H code in the RPSTL.

DEPOT level—corresponds to a D code in the RPSTL.

b. Unit *Maintenance*. Maintenance to be performed in the Unit level is described as follows:

(1) Unit Maintenance activities are staffed and equipped to perform high frequency on equipment maintenance tasks required to retain or return equipment to a serviceable condition. These tasks include preventive maintenance and repair and replace functions associated with a high level of mission capability.

(2) Unit Maintenance inspection and servicing include daily (usually performed by operator or crew), periodic, and special inspections, as authorized by the MAC or higher headquarters.

(3) Unit level maintains a Combat Prescribed Load List (PPL) which consists of items on the Mandatory Parts List (MPL) and items which are demand supported.

(4) Unit level performs troubleshooting, replace, and limited repair functions as authorized by the MAC, RPSTL, and applicable technical manuals.

c. *Intermediate Maintenance*. Maintenance to be performed in the Intermediate level is described as follows:

(1) One stop maintenance support through use of mobile weapon system oriented maintenance teams to perform authorized maintenance (that exceeds Unit level capability) to effect quick repair and return to user capabilities.

(2) Maintains a Combat Authorized Stockage List (ASL), Mandatory Parts List (MPL), Direct Exchange (DX), and provides limited Operational Readiness Float (ORF) for supported units.

(3) *Provides collection*, classification, and recovery services for serviceable and unserviceable material and maintains a Battle Damage Assessment (BDA) capability.

(4) Provides maintenance support for the theater supply system through repair of components and DX items.

(5) Provides maintenance units composed of commodity oriented platoons which maybe augmented by support teams that deploy forward if the tactical situation permits.

(6) Maintains Operational Readiness Float (ORF) stocks in support of the theater.

d. Depot Maintenance. Depot level functions are authorized as indicated by entries in the Depot(D) Maintenance level column (4) in the MAC.

B-2. USE OF THE MAINTENANCE ALLOCATION CHART, SECTION II

a. The MAC assigns maintenance functions based on the following considerations:

- (1) Skills available.
- (2) Work time required.
- (3) Tools and test equipment required and/or available.

b. If a lower level of maintenance identified in column (4) of the MAC cannot perform all tasks of a single maintenance function (e.g., test, repair), then the higher level that can perform other tasks of that function is also indicated.

c. Higher maintenance levels are automatically authorized to perform maintenance functions assigned to a lower maintenance level.

d. Higher maintenance levels will perform the maintenance functions of lower maintenance levels when required or directed by the Commander who has authority to direct such tasking.

e. Assignment of a maintenance function in the MAC does not carry automatic authorization to carry the related spare or repair parts in stock. Information to requisition or secure parts will be as specified in the associated RPSTL.

f. Normally, there will be no deviation from the assigned level of maintenance. However, in cases of operational necessity, maintenance functions assigned a higher level may, at the request of the lower level, be assigned to the lower level on a one-time basis, if specifically authorized by the maintenance officer of the higher level to which the function is assigned. In such a case, the special tools, equipment, etc., required by the lower level to perform this function will be furnished by the higher level assigned the function. Also, transfer of a function to a lower level does not relieve the higher level of responsibility for the function, so the higher level will provide technical supervision and inspection of the function being performed at the lower level.

B-3. MAINTENANCE FUNCTIONS

Maintenance functions will be limited to and defined as follows:

a. *Inspect*. Two levels of inspect are covered in the MAC.

(1) When prescribed at the C or O element of Unit Maintenance level, inspect means to determine serviceability by comparing an item's physical, mechanical, and/or electrical characteristics with established standards through examination (i.e., by sight, sound, or feel). These inspections are included in preventive maintenance (PM) checks and services, such as PMCS, PMD.

(2) When prescribed at the Intermediate (F) or Depot (D) maintenance level, inspect refers to an initial inspection which is conducted prior to scheduling any repair on repairable items evacuated to this level. This inspection is made to determine whether an item qualifies for repair or discard.

b. *Test*. To verify serviceability and detect incipient failure by measuring the mechanical or electrical characteristics of an item and comparing those characteristics with prescribed standards.

e. Column 5, Tools and Equipment. Column 5 specifies, by code, those common tool sets (not individual tools) and special tools, TM DE, and support equipment required to perform the designated function.

f. Column 6, Remarks. This column shall, when applicable, contain a letter code, in alphabetic order, which shall be keyed to the remarks contained in Section IV.

B-4. EXPLANATION OF COLUMNS IN TOOL AND TEST EQUIPMENT REQUIREMENTS, SECTION III

a. Column 1, Reference Code. The tool and test equipment reference code correlates with a code used in the MAC, Section II, Column 5.

b. Column 2, Maintenance Category. The lowest category of maintenance authorized to use the tool or test equipment.

c. Column 3, Nomenclature. Name or identification of the tool or test equipment,

d. Column 4, Tool Number. The manufacturer's part number.

B-5. EXPLANATION OF COLUMNS IN REMARKS, SECTION IV

a. Column 1, Reference Code. The code recorded in column 6, Section II.

b. Column 2, Remarks. This column lists information pertinent to the maintenance function being performed as indicated in the MAC, Section II.

- c. *Service*. Operations required periodically to keep an item in proper operating condition, i.e., to clean (includes decontaminate), to preserve, to drain, or to replenish fuel, lubricants, hydraulic fluids, or compressed air supplies.
- d. *Adjust*. To maintain within prescribed limits, by bringing into proper or exact position, or by setting the operating characteristics to the specified parameters.
- e. *Align*. To adjust specified variable elements of an item to bring about optimum or desired performance.
- f. *Calibrate*. To determine and cause corrections to be made or to be adjusted on instruments or test measuring and diagnostic equipment used in precision measurement. Consists of comparison of two instruments, one of which is a certified standard of known accuracy, to detect and adjust any discrepancy in the accuracy of the instrument being compared.
- g. *Install*. The act of emplacing, seating, or fixing into position an item, part, or module (component or assembly) in a manner to allow the proper functioning of an equipment or system.
- h. *Replace*. The act of substituting a serviceable like type part, a subassembly, or module (component or assembly) for an unserviceable counterpart.
- i. *Repair*. The application of maintenance services (inspect, test, service, adjust, align, calibrate or replace) or other maintenance actions (welding, grinding, riveting, straightening, facing, remachining, or resurfacing) to restore serviceability to an item by correcting specific damage, fault, malfunction, or failure in a part, subassembly, module (component or assembly), end item, or system.
- j. *Overhaul*. That maintenance effort (service/action) necessary to restore an item to a completely serviceable operational condition as prescribed by maintenance standards in appropriate technical publications (i.e., DMWR). Overhaul is normally the highest degree of maintenance performed by the Army. Overhaul does not normally return an item to a like new condition.
- k. *Rebuild*. Consists of those services/actions necessary for the restoration of unserviceable equipment to a like new condition in accordance with original manufacturing standards. Rebuild is the highest degree of material maintenance applied to Army equipment. The rebuild operation includes the act of returning to zero those age measurements (hours/miles, etc.) considered in classifying Army equipment/components.

B-4. EXPLANATION OF COLUMNS IN THE MAC, SECTION II

- a. *Column (1), Group Number*. Column 1 lists functional group code numbers which are assigned to identify maintenance significant components, assemblies, subassemblies, and modules to their next higher assembly.
- b. *Column (2), Component/Assembly*. Column 2 contains the item names of components, assemblies, subassemblies, and modules for which group numbers (column 1) are assigned and for which maintenance is authorized.
- c. *Column (3), Maintenance Function*. Column 3 lists the functions to be performed on items listed in column 2. (Function definitions are contained in paragraph B-3).
- d. *Column (4), Maintenance Level*. The maintenance levels, Unit, intermediate, and Depot, are allotted separate subcolumns within column 4. Entry of a work time figure (such as 1.0, 0.2) in a subcolumn indicates that that level is authorized to perform the function listed in column 3, and the average time required to do the function is the work time figure. If the number or complexity of tasks within a maintenance function varies from one maintenance level to another, the applicable work time figure for each level will be entered for that function. The work time figure represents the average time it takes to restore a component/assembly to a serviceable condition under a typical field operating environment.

e Column (5), Tools and Equipment. Column 5 specifies, by code, common tool sets (not individual tools from those sets), common TM DE, and special tools, TMDE, and support equipment required to perform a designated function. The code in Column 5 keys to the listing in Section III of the MAC.

f. Column (6), Remarks. This column, when applicable, contains a letter code which is keyed to an explanation of the code contained in Section IV of the MAC.

B-5. EXPLANATION OF COLUMNS IN THE MAC, SECTION III

a. Column (1), Tool or Test Equipment Reference Code. The tool or test equipment reference code correlates with a code used in the MAC, Section II, Column 5.

b. Column (2), Maintenance Category. The lowest category of maintenance authorized to use the tool or test equipment.

c. Column (3), Nomenclature. Name or identification of the tool or test equipment.

d. Column (4), National/NATO Stock Number. The national stock number of the tool or test equipment.

e. Column (5), Tool Number. The manufacturer's part number.

B-6. EXPLANATION OF COLUMNS IN THE MAC, SECTION IV

a. Column (1), Reference Code. The code recorded in Column 6, Section II.

b. Column (2), Remarks. This column lists information pertinent to the maintenance function being Performed as indicated in the MAC, Section II.

Section II. MAINTENANCE ALLOCATION CHART									
NOMENCLATURE OF END ITEMS:									
(1) GROUP NUMBER	(2) COMPONENT/ ASSEMBLY	(3) MAINTENANCE FUNCTION	(4) MAINTENANCE LEVEL					(5) TOOLS AND EQUIPMENT	(6) REMARKS
			UNIT		INTERMEDIATE		DEPOT		
			C	O	F	H	D		
00	Range Outfit, Field, Gasoline, Model M59								
01	Cabinet Assembly	Inspect	0.2						
		Service	1.0						
		Replace			4.0				
01	Lid Assembly	Repair			8.0			2	
		Inspect	0.1						
		Replace		0.2				2	
01	Door Assembly	Repair			1.0			2	
		Inspect	0.2						
		Replace			0.8			2	
01		Repair			1.5			2	
		Inspect	0.1						
		Replace		0.1					
02	Cabinet Component Items	Inspect	0.1						
03	Accessory Outfit Items	Replace		0.1					
		Inspect	0.1						
		Replace		0.1					
03	Rack Set, Bake	Inspect	0.1						
		Service	0.4						
		Replace		0.1					
03		Repair		0.4				2	
		Inspect	0.6						
		Service	0.5						
04	Burner Unit Assembly	Adjust	0.1					1	
		Replace		0.1					
		Repair		0.9				2	
04	Generator Assembly	Inspect	0.1						
		Service	0.2						
		Replace	0.1						
04	Preheater Assembly	Repair	0.2					1	
		Inspect	0.1						
		Service	0.1						
04		Replace		0.2				2	
		Repair		0.2				2	

Section II. MAINTENANCE ALLOCATION CHART

NOMENCLATURE OF END ITEMS:

(1) GROUP NUMBER	(2) COMPONENT/ ASSEMBLY	(3) MAINTENANCE FUNCTION	(4) MAINTENANCE LEVEL					(5) TOOLS AND EQUIPMENT	(6) REMARKS
			UNIT		INTERMEDIATE		DEPOT		
			C	O	F	H	D		
	Gage, Pressure	Inspect Test Replace	0.1 0.2	0.3				2	
	Tank Assembly, Fuel	Inspect Service Replace Repair	0.1 0.2	0.4 0.5				2	A B
	Cap Assembly, Filler	Inspect Service Replace Repair	0.1 0.1	0.1 0.2				2 2	A
	Air Valve Assembly	Inspect Replace Repair	0.1 0.2	0.2				2	
	Frame Assembly	Inspect Service Replace	0.1 0.1	0.4				2	A
	Safety Valve Device	Inspect Test Replace	0.2	0.2 0.5				2	

Section III. TOOL AND TEST EQUIPMENT REQUIREMENTS

Reference code	Maintenance category	Nomenclature	Tool number
1	C	WRENCH, COMBINATION, Removal and adjustment of burner valves.	5120-00-303-7737
2	O	TOOL KIT, General Mechanic's Automotive.	5180-00-177-7033

IV. REMARKS

Reference Code	Remarks
A	Service includes cleaning.
B	No repair is authorized at any maintenance level, to the body of the fuel tank assembly, such as welding, drilling, or soldering.

APPENDIX C

COMPONENTS OF END ITEM LIST

Section I. INTRODUCTION

C-1. SCOPE.

This appendix lists integral components of and basic issue items for the range outfit to help you inventory items required for safe and efficient operation.

C-2. GENERAL.

The Components of End Item List is divided into the following sections:

a. *Section II. Integral Components of the End Item.* These items, when assembled, comprise the range outfit, accessory outfit and burner unit and must accompany it whenever it is transferred or turned in. The illustrations will help you identify these items.

b. *Section III. Basic Issue Items.* These are the minimum essential items required to place the range outfit in operation, to operate it, and to perform emergency repairs. Although shipped separately packed they must accompany the range outfit during operation and whenever it is transferred between accountable officers. The illustrations will assist you with hard-to-identify items. This manual is your authority to requisition replacement B11, based on TOE/ MTOE authorization of the end item.

C-3. EXPLANATION OF COLUMNS.

a. *Illustration.* This column is divided as follows:

- (1) *Figure Number.* Indicates the figure number of the illustration on which the item is shown.
- (2) *Item Number.* The number used to identify item called out in the illustration.

b. *National Stock Number.* Indicates the National Stock Number assigned to the item and which will be used for requisitioning.

c. *Part Number.* Indicates the primary number used by the manufacturer which controls the design and characteristics of the item by means of its engineering drawings, specification, standards, and inspection requirements to identify an item or range of items.

d. *Description.* Indicates the Federal item name and, if required, a minimum description to identify the item.

e. *Usable on Code.* ‘‘USABLE ON’’ codes are included to help you identify which component items are used on the different models. Identification of the codes used in these lists are:

Code	Used On
BEC	Model M59
BED	Model M2, M2A and M2A with Safety Device.
BZZ	Accessory Outfit with Baking Rack

f. *Quantity Required (Qty Reqd).* This column lists the quantity of each item required for a complete major item.

g. *Quantity.* This column is left blank for use during an inventory. Under the Rcv'd column, list the quantity you actually receive on your major item. The Date columns are for your use when you inventory the major item at a later date such as for shipment to another site.

SECTION II. INTEGRAL COMPONENTS OF END ITEM

(1) ILLUSTRATION		(2)	(3)	(4)	(5)	(6)	(7)
(A) FIG. NO.	(B) ITEM NO.	NATIONAL STOCK NUMBER	PART NUMBER & FSCM	DESCRIPTION / LOCATION		USABLE ON CODE	QTY REQD
Range Outfit, Field, Gasoline, Model M59							
D-2	1	7330-00-292-2307	2-09-120 (81349)	POT, COOKING, 15 GAL		BEC	1 EA
D-2	2	7330-00-292-2306	2-09-35 (81349)	POT, COOKING, 10 GAL		BEC	1 EA
D-2	3	7330-00-263-8516	A-A-52201 ITEM 2 (81349)	COVER, BAKING AND ROASTING PAN		BEC	1 EA
D-2	4	7330-00-379-2495	5-11-71-34 (81337)	CRADLE, COOK POT		BEC	1 EA
D-2	5	7330-00-272-2489	A-A-1752 TYPE II SIZE 1 (81349)	DIPPER, KITCHEN		BEC	2 EA
D-2	6	7330-00-248-1153	A-A-1956 SIZE 3 (81349)	LADLE, KITCHEN		BEC	2 EA
D-2	7	7330-00-680-2635	A-A-1072 (58536)	SKIMMER, KITCHEN		BEC	1 EA
D-2	8	7330-00-634-1995	A-A-1640 TYPE I STYLE A (81348)	TURNER, FOOD		BEC	1 EA
D-2	9	7330-00-238-8316	A-A-1953 (81349)	PEELER, POTATO, HAND		BEC	2 EA
D-2	10	7330-00-272-7876	A-A-1954 (81349)	MEASURING SET, SPOON (CRS)		BEC	2 EA
D-2	11	7340-00-488-7939	A-A-2733 TYPE V (81348)	KNIFE, PARING		BEC	2 EA
D-2	12	7340-00-197-1271	A-A-2733 TYPE III (81348)	KNIFE, BONING		BEC	2 EA
D-2	13	7340-00-488-7950	A-A-2733 TYPE IV (81348)	KNIFE, COOK'S		BEC	2 EA
D-2	14	7330-00-680-0865	A-A-1956 SIZE 2	LADLE			1 EA
D-2	15	7340-00-223-7800	A-A-52204 TYPE II SIZE 2 (81348)	SPOONS, BASTING		BEC	2EA

SECTION II. INTEGRAL COMPONENTS OF END ITEM - Continued

(1) ILLUSTRATION		(2)	(3)	(4)	(5)	(6)	(7)
(A) FIG NO.	(B) ITEM NO.	NATIONAL STOCK NUMBER	PART NO. & FSCM	DESCRIPTION /	LOCATION	USABLE ON CODE	QTY REQD
D-2	16	7340-00-223-7791	A-A-52204 TYPE 1 SIZE 1 (81348)	FORK, FOOD PREPARATION		BEC	2 EA
D-2	17	7330-00-550-7592	A-A-2733 TYPE X	BUTCHER'S STEEL		BZZ	1 EA
D-2	18	7330-00-205-1950	A-A-52068	SCRAPER, BAKER'S		BZZ	1 EA
D-2	19	7330-00-272-2589		PAN, RECTANGULAR		BEC	2 EA
D-2	20	7330-00-250-6300	2-09-35 (81349)	COVER, COOK POT		BEC	2 EA
D-2	21	7340-00-255-0702	A-A-1082 TYPE II, SIZE 2	SPOON, FOOD SERVICE (STRAINING)		BEC	1 EA
D-2	22	7330-00-485-7376	A-A-52201 ITEM 1, (81349)	PAN, BAKING AND ROASTING, DEEP		BEC	1 EA
D-2	23	7330-00-148-7173	A-A-52201 ITEM 3, (81349)	WARMER ADAPTER (OPTIONAL)**		BEC	1 EA
D-2	24		5-11-353-7 (81337)	RACK, BOTTOM		BZZ	1 EA
D-2	25	7330-00-815-1458	A-A-394 (81348)	WHIP, EGG		BZZ	1 EA
D-2	26			WARMER, ADAPTER		BEC	1 EA
D-2	27	7360-00-106-5965	5-11-353 (81337)	RACK SET, BAKE		BZZ	1 EA
D-2	28		5-11-353-6 (81337)	RACK, TOP		BZZ	1 EA
D-2	29		5-11-353-5 (81337)	HOOK, CHAIN, MIDDLE RACK		BZZ	4 EA
D-2	30		5-11-353-1 (81337)	MIDDLE RACK MTG		BZZ	4 EA
D-2	31		5-11-353-3 (81337)	SCREW, MACHINE		BZZ	4 EA
D-2	32		5-11-353-8 (81337)	RACK, MIDDLE		BZZ	1 EA
D-2	33		5-11-353-2 (81337)	WASHER, LOCK		BZZ	4 EA
D-2	34		5-11-353-4 (81337)	NUT, PLAIN HEXAGON		BZZ	4 EA
D-2	35		5-11-353-7 (81337)	RACK, BOTTOM		BZZ	1 EA
Accessory Outfit, Gasoline Field Range (one for every one to four ranges)							
D-3	1	5120-00-224-3154	ANSI B107.6 (96906)	BOX, WRENCH		BZZ	1 EA
D-3	2	5345-00-198-8040	A-A-3068/3 (81348)	STONE, SHARPENING		BZZ	1 EA
D-3	3	5120-00-222-8852	ANSI B107.15 (96906)	SCREWDRIVER, FLAT TIP		BZZ	2 EA
D-3	4		5-11-2075-1 (81337)	CHEST, TOOL		BZZ	1 EA
D-3	5	4320-00-852-9036	A-A-2888 (81348)	PUMP, INFLATING		BZZ	1 EA
D-3	6	5120-00-240-5328	A-A-2344 (81348)	WRENCH, ADJUSTING CRESCENT		BZZ	1 EA
D-3	7	7920-00-291-5815	A-A-3118 (81348)	BRUSH, WIRE		BZZ	1 EA
D-3	8	5120-00-379-2490	5-11-907 (81349)	CLEANER, BURNER, SLOT		BZZ	1 EA
D-3	9	7360-00-402-2403	5-11-964 (81349)	PROTECTOR, ARM, GASOL		BEC	1 EA
D-3	10	7360-00-402-4495	5-11-964 (81349)	PROTECTOR, ARM, GASOL		BEC	1 EA
D-3	11	8030-00-087-8630	*MIL-T-83483 (81349)	ANTISEIZE, COMPOUND		BZZ	1 EA
D-3	12	9150-00-252-6173	*VV-L-800 (81348)	LUBRICATING OIL, GEN		BZZ	1 EA
D-3	13	4210-00-270-4512	UL154 (81348)	EXTINGUISHER, FIRE		BZZ	2 EA
D-3	14	7330-00-205-3151	A-A-52206 (81348)	OPENER, CAN		BZZ	1 EA
D-3	15	7330-00-999-2552	5-11-1232PC5-10 (81317)	GENERATOR, PREHEATER		BZZ	1 EA
D-3	16	5120-00-303-7737	2-9-108 (81337)	WRENCH, ASSEMBLY		BZZ	1 EA
D-3	17	5120-00-234-8913	ANSI B107.15 (96906)	SCREWDRIVER, CROSS TIP		BZZ	1 EA
D-3	18	7240-00-177-6154		SPOUT, CAN, FLEXIBLE		BZZ	1 EA
D-3	19	5120-00-770-0030	*GGG-W-657 (81348)	NUT DRIVER 7/16 INCH ***		BZZ	1 EA
D-3	20	7920-00-514-2417	A-A-289, TYPE 2 (81348)	BRUSH, CLEANING ***		BZZ	1 EA

* For reference only

** Use item 23 when metal insulated food containers with inserts (NSN 7330-00-238-2411) are being used.

*** Used only with the Modern Burner Unit (MBU). For information on the Modern Burner Unit (MBU) refer to TM 10-7360-281-13&P.

TM 10-7360-204-13&P

SECTION II. INTEGRAL COMPONENTS OF END ITEM - Continued

(1)		(2)	(3)	(4)	(5)	(6)	(7)
ILLUSTRATION		NATIONAL STOCK NUMBER	PART NO. & FSCM	DESCRIPTION /	LOCATION	USABLE ON CODE	QTY REQD
(A) FIG NO.	(B) ITEM NO.						
Burner Unit, Gasoline, Model M2, M2A, or M2A with Safety Device							
D-4	10	7310-00-999-2495	5-11-1238 PC9 (81337)	GENERATOR ASSEMBLY		BED	2 EA
D-4	20	7310-00-999-2511	5-11-1244-23 (81337)	SHIELD ASSEMBLY, PREHEATER		BED	1 EA

APPENDIX D

REPAIR PARTS AND SPECIAL TOOLS LIST

Section I. INTRODUCTION

D-1. SCOPE.

This manual lists repair parts; special tools; special test, measurement, and diagnostic equipment (TMDE), and other special support equipment required for performance of organization, and depot maintenance of the field range outfit. It authorizes the requisitioning and issue of repair parts as indicated by the source and maintenance codes.

D-2. GENERAL.

This Repair Parts and Special Tools List is divided into the following sections:

a. Section II. Repair Parts List. A list of repair parts authorized for use in the performance of maintenance. The list also includes parts which must be removed for replacement of the authorized parts. Parts lists are composed of functional groups in numeric sequence, with the parts in each group listed in figure and item number sequence. Bulk materials are listed in NSN sequence.

b. Section III. Special Tools List. A list of special tools, special TMDE, and other special support equipment authorized for the performance of maintenance (Not Applicable.)

c. Section IV. National Stock Number and Part Number Index. A list, in National Item Identification Number (NIIN) sequence, of all National Stock Numbers (NSN) appearing in the listings, followed by a list in alphanumeric sequence of all part numbers appearing in the listings. National stock numbers and part numbers are cross-referenced to each illustration figure and item number appearance. This index is followed by a cross-reference list of reference designators to figure and item numbers.

D-3. EXPLANATION OF COLUMNS.

a. Illustration. This column is divided as follows:

(1) *Figure Number.* Indicates the figure number of the illustration of which the item is shown.

(2) *Item Number.* The number used to identify item called out in the illustration.

b. Source, Maintenance, and Recoverability (SMR) Codes.

(1) *Source Code.* Source codes indicate the manner of acquiring support items for maintenance, repair, or overhaul of end items.

Source codes are entered in the first and second positions of the Uniform SMR code format as follows:

Code	Definition
PA	Item procured and stocked for anticipated or known usage.
PB	Item procured and stocked for insurance purposes because essentiality dictates that a minimum quantity be available in the supply system.
PC	Item procured and stocked and which otherwise would be coded PA except that it is deteriorative in nature.
PD	Support item, excluding support equipment, procured for initial issue or outfitting and stocked only for subsequent or additional initial issues or outfitting. Not subject to automatic replenishment.
PE	Support equipment procured and stocked for initial issue or outfitting to specified maintenance repair activities.

Code	Definition
PF	Support equipment which will not be stocked but which will centrally procured on demand.
PG	Item procured and stocked to provide for sustained support for life of the equipment. It is applied to an item peculiar to the equipment which, because of probable discontinuance or shutdown of production facilities, would prove uneconomical to reproduce at a later date,
KD	An item of depot overhaul/repair kit and not purchased separately. Depot kit defined as a kit that provides items required at the time of overhaul or repair.
KF	An item of a maintenance kit and not purchased separately. Maintenance kit defined as a kit that provides an item that can be replaced at organizational or intermediate levels of maintenance.
KB	Item included in both a depot overhaul/repair kit and a maintenance kit.
MO	Item to be manufactured or fabricated at organizational level.
MF	Item to be manufactured or fabricated at the direct support maintenance level.
MH	Item to be manufactured or fabricated at general maintenance support level.
MD	Item to be manufactured or fabricated at depot maintenance level.
AO	Item to be assembled at organizational level,
AF	Item to be assembled at direct support maintenance level.
AH	Item to be assembled at general support maintenance level.
AD	Item to be assembled at depot maintenance level.
XA	Item is not procured or stocked because the requirements for the item will result in replacement of the next higher assembly.
XB	Item not procured or stocked. If not available through salvage, requisition.
XD	A support item that is not stocked. When required, item will be procured through normal supply channels.

NOTE

Cannibalization or salvage may be used as a source of supply for any items coded above except those coded XA and support items restricted by AR 700-42.

(2) *Maintenance Code.* Maintenance codes are assigned to indicate the levels of maintenance authorized to USE and REPAIR support items. The maintenance codes are entered in the third and fourth **positions** of the Uniform SMR Code format as follows:

(a) The Maintenance Code entered in the third position will indicate the lowest maintenance level authorized to remove, replace, and use the support item. The maintenance code entered in the third position will indicate one of the following levels of maintenance.

Code	Application/Explanation
c	- Crew or operator maintenance performed within organizational maintenance.
o	- Support item is removed, replaced, used at the organizational level.
I	- Support item is removed, replaced, used by the direct support element of integrated direct support maintenance.
F	- Support item is removed, replaced, used at the direct support level.
H	- Support item is removed, replaced, used at the general support level.
D	- Support items that are removed, replaced, used at depot, mobile depot, or specialized repair activity only.

NOTE

Codes I and F will be considered the same by direct support units.

(b) The maintenance code entered in the fourth position indicates whether the item to be repaired and identifies the lowest maintenance level with the capability to perform complete repair (i.e., all authorized maintenance functions). This position will contain one of the following maintenance codes.

Code	Application/Explanation
o	The lowest maintenance level capable of complete repair of the support item is the organization level.
F	The lowest maintenance level capable of complete repair of the support item is the direct support level.
H	The lowest maintenance level capable of complete repair of the support item is the general support level.
D	The lowest maintenance level capable of complete repair of the support item is the depot level.
L	Repair restricted to designated, Specialized Repair Activity.
z	Nonreparable. No repair is authorized.
B	No repair is authorized. The item may be reconditioned by adjusting, lubricating, etc., at the user level. No parts or special tools are procured for the maintenance of this item.

(3) *Recoverability Codes.* Recoverability codes are assigned to support items to indicate the disposition action on unserviceable items. The recoverability code is entered in the fifth position of the Uniform SMR Code format as follows:

Recoverability Code	Definition
Z	- Non-reparable item. When unserviceable, condemn and dispose at the level indicated in position three (3).
O	- Repairable item. When uneconomically repairable, condemn and dispose at organizational level.
F	- Repairable item. When uneconomically repairable, condemn and dispose at direct support level.
H	- Repairable item. When uneconomically repairable, condemn and dispose at general support level.
D	- Repairable item. When beyond lower level repair capability, return to depot. Condemnation and disposal not authorized below depot level.
L	- Repairable item. Repair, condemnation, and disposal not authorized below depot/specialized repair activity level.
A	- Item requires special handling or condemnation procedures because of specific reasons (i.e., precious metal content, high dollar value, critical material, or hazardous material). Refer to appropriate manuals/directives for specific instructions.

c. *Natinoal Stock Number.* Indicates the National Stock Number assigned to the item and which will be used for requisitioning.

d. *Part Number.* Indicates the primary number used by the manufacturer (individual, company, firm, corporation, or Government activity), which control the design and characteristics of the item by means of its engineering drawings, specifications, standards, and inspection requirements to identify an item or range of items.

NOTE

When a stock numbered item is requisitioned, the item received may have a different part number than the part being replaced.

e. *Federal Supply Code for Manufacturer (FSCM).* The FSCM is a 5-digit numeric code listed in SB 708-42; which is used to identify the manufacturer, distributor, or Government agency, etc.

f. Description. Indicates the Federal item name and, if required, a minimum description to identify the items. Items that are included in kits and sets are listed below the name of the kit or set with the quantity of each item in the kit or set indicated in the quantity incorporated in unit column.

g. Unit of Measure (U/M). Indicates the standard or basic quantity of the listed item as used in performing the actual maintenance function. This measure is expressed by a two-character alphabetical abbreviation (e.g., ea, in, pr, etc.). When the unit of measure differs from the unit of issue, the lowest unit of issue that will satisfy the required units of measure will be requisitioned.

h. Quantity Incorporated in Unit. Indicates the quantity of the item used in the breakout shown on the illustration figure, which is prepared for functional group, subfunctional group, or an assembly. A "V" appearing in this column in lieu of a quantity indicates that no specific quantity is applicable, (e.g., shims spacers, etc.).

D-4. SPECIAL INFORMATION.

Usable On Code. "USABLE ON" codes are included to help you identify which component items are used on the different models. Identification of the codes used in these lists are:

Code	Used On
BEC	Model M59
BED	Model M2, M2A and M2A with Safety Device.
BZZ	Accessory Outfit with Baking Rack

D-5. HOW TO LOCATE REPAIR PARTS.

a. When National Stock Number or Part Number is Unknown:

(1) Using the table of contents determine the assembly group within which the repair part belongs. This is necessary since illustrations are prepared for assembly groups, and listings are divided into the same group.

(2) Find the illustration covering the assembly group to which the repair part belongs.

(3) Identify the repair part on the illustration and note the illustration figure number and item number of the repair part.

(4) Using the repair parts listing, find the assembly group to which the repair part belongs and locate the illustration figure and item number noted on the illustration.

b. When National Stock Number of Part Number is Known:

(1) *First.* Using the Index of National Stock Numbers and Part Numbers, find the pertinent National Stock Number or Part Number. This index is in NIIN sequence followed by a list of part numbers in alphanumeric sequence, cross-referenced to the illustration figure number and item number.

(2) *Second.* After finding the figure and item number, locate the figure and item number in the repair parts list.

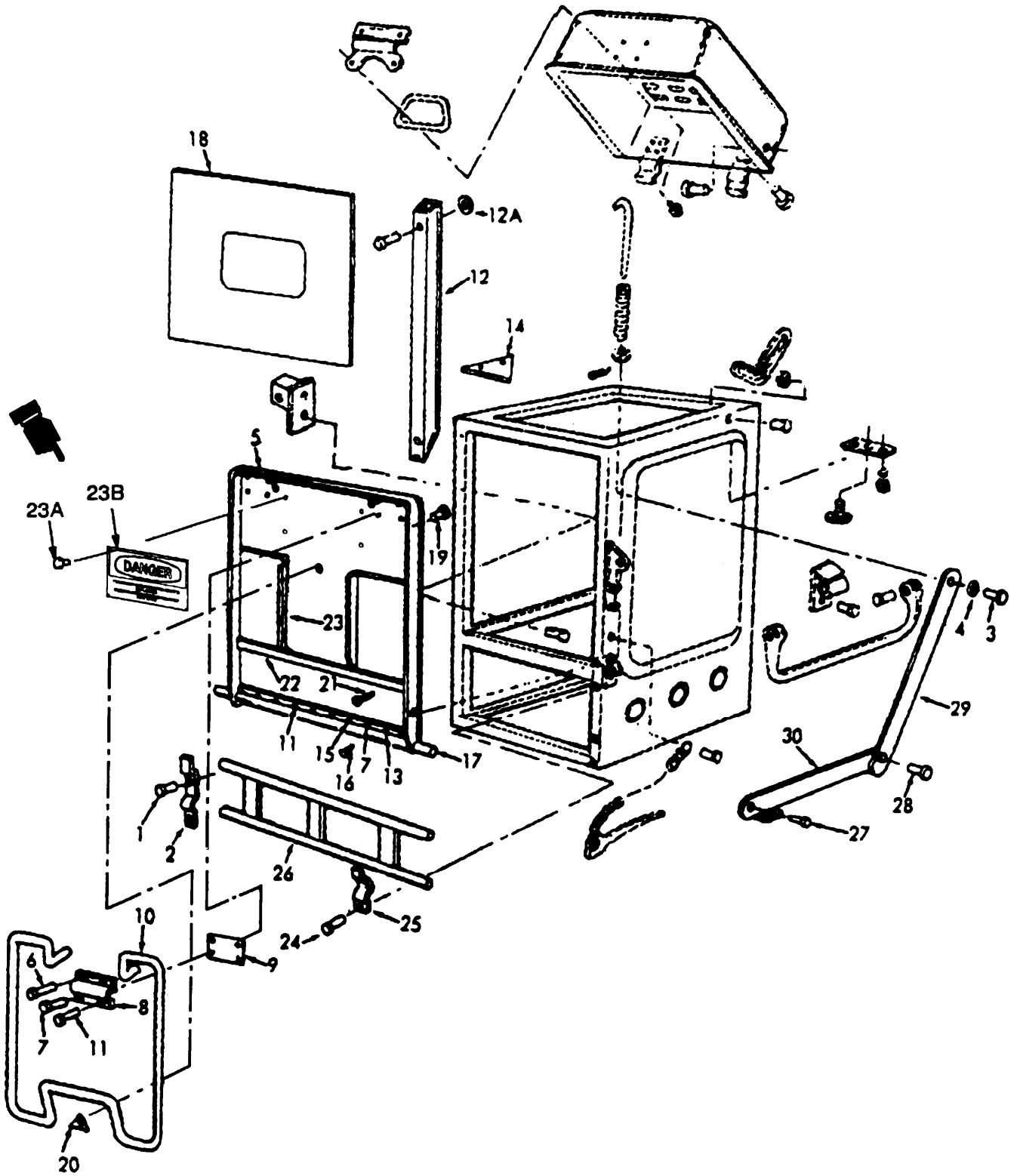

Figure D-1. Cabinet Assembly (Sheet 1 of 3)

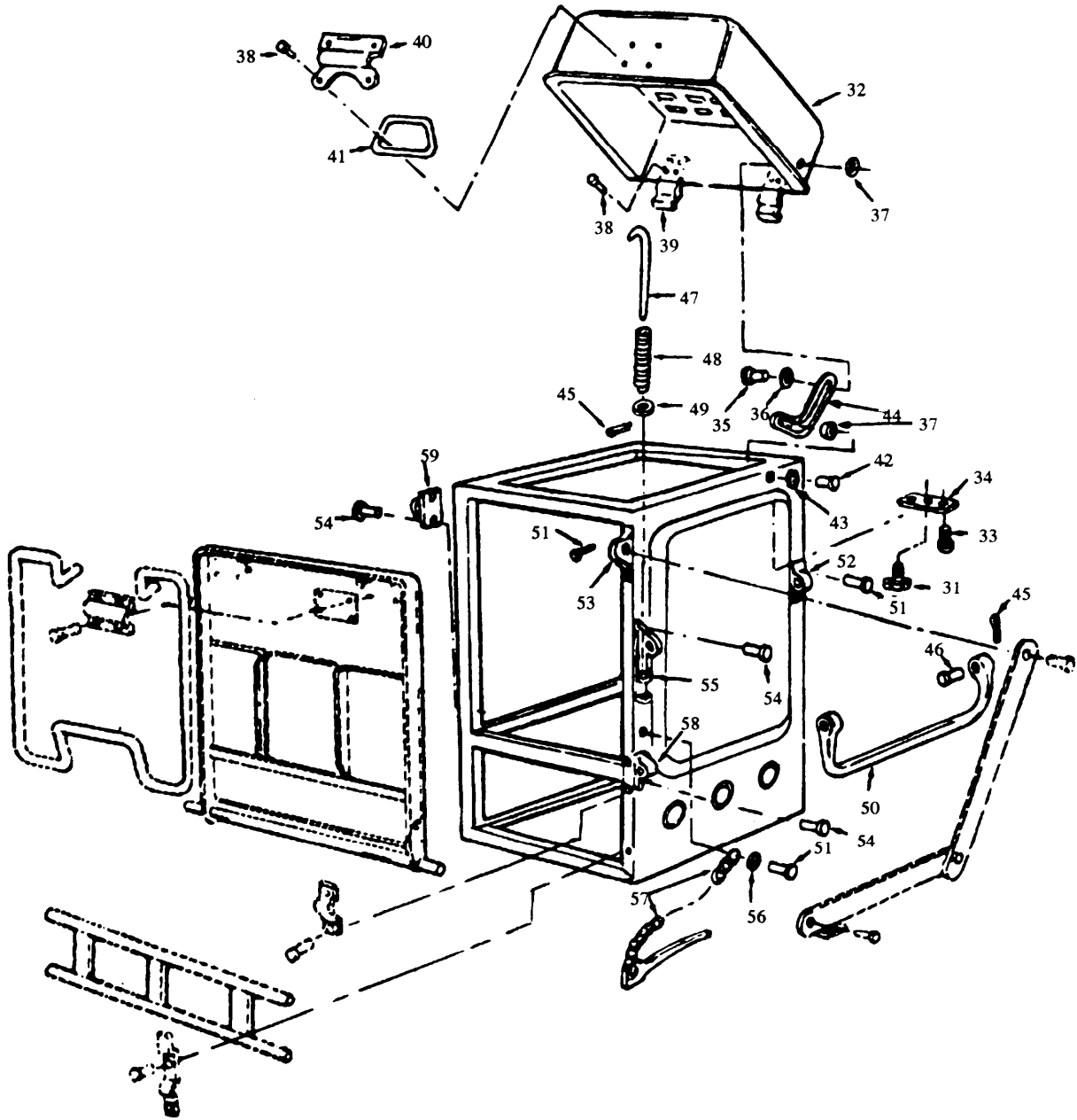

Figure D-1. Cabinet Assembly (Sheet 2 of 3)

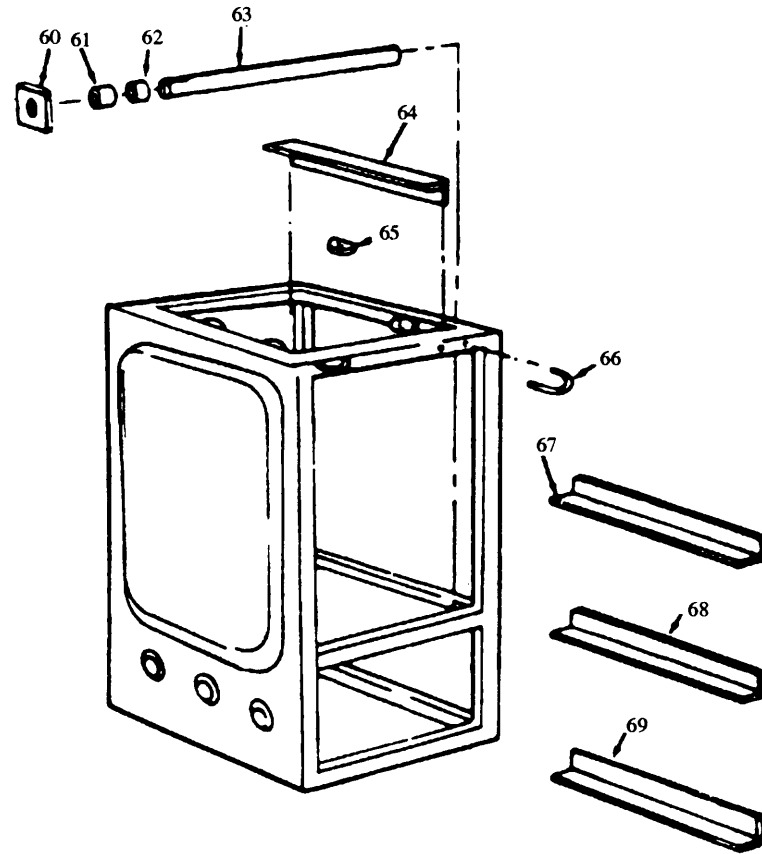

Figure D-1. Cabinet Assembly (Sheet 3 of 3)

(1) ILLUSTRATION		(2) SMR CODE	(3) NATIONAL STOCK NUMBER	(4) PART NUMBER	(5) FSCM	(6) DESCRIPTION USABLE ON CODE	(7) U/M	(8) QTY INC IN UNIT
(A) FIG NO.	(B) ITEM NO.							
						Section II – Repair Parts List Group 01 – CABINET ASSEMBLY		
D-1		PAFFF	7360-00-702-1719	5-11-414	81349	Cabinet, Gasoline, Field, Range Outfit	BEC	EA 1
D-1	1	PBFZZ	4320-00-069-1808	5-11-414-32	81337	Rivet Retainer Bar	BEC	EA 4
D-1	2	XBFZZ	5340-01-109-7884	5-11-910-8	81337	Bracket Hinge Bar	BEC	EA 2
D-1	3	PBFZZ	5320-00-909-7883	5-11-419-6-28	81337	Rivet, Stay, Upper	BEC	EA 2
D-1	4	PAFZZ		5-11-419-6-27	81337	Burr, Riveting, Upper Stay Lid	BEC	EA 1
D-1	5	PAFFF	7360-00-999-9882	5-11-419-6	81337	Door Assembly, (Upper)	BEC	EA 1
D-1	6	PBFZZ	5320-00-837-3473	5-11-419-6-38	81337	Rivet, Door, Solid	BEC	EA 4
D-1	7	PBFZZ	5320-00-772-3949	5-11-419-6-18	81337	Rivet, Door, Solid	BEC	EA 4
D-1	8	XBFZZ		5-11-420-6-36	81337	Bracket Assembly, L.H.Door	BEC	EA 1
D-1	9	XBFZZ		5-11-420-6-37	81337	Wear Plate Door	BEC	EA 2
D-1	10	PBFZZ	5340-00-999-9887	5-11-420-6-19	81337	Latch, Door	BEC	EA 1
D-1	11	PBFZZ	5320-00-754-0994	5-11-420-6-16	81337	Rivet, Door, Latch	BEC	EA 5
D-1	12	XBFZZ		5-11-420-6-21	81337	Slide, Cradle, R.H.	BEC	EA 1
D-1	12	XBFZZ		5-11-420-6-22	81337	Slide, Cradle, L.H.	BEC	EA 1
D-1	12A	XBFZZ		5-11-419-6-40	81337	Spacer, Cradle Slide	BEC	EA 2
D-1	13	PBFZZ	5320-00-069-1808	5-11-419-6-17	81337	Rivet, Door Hinge	BEC	EA 9
D-1	14	XBFZZ		5-11-420-6-15	81337	Gusset, Door Frame	BEC	EA 2
D-1	15	XBFZZ		5-11-420-6-11	81337	Hinge, Door	BEC	EA 1
D-1	16	XBFZZ		5-11-419-6-20	81337	Rivet, Door, Bar	BEC	EA 2
D-1	17	XBFZZ		5-11-420-6-12	81337	Bar, Hinge, Door	BEC	EA 1
D-1	18	XBFZZ		5-11-421-6-2	81337	Sheet, Inside	BEC	EA 1
D-1	19	PAFZZ	5320-01-237-2696	5-11-419-6-42	81337	Rivet, Blind	BEC	EA 2
D-1	20	XBFZZ		5-11-420-6-13	81337	Spacer, Slide	BEC	EA 2
D-1	21	PAFZZ	5320-00-129-9706	*MIL-R-24243/1-F402	81337	Rivet, Blind	BEC	EA 4
D-1	22	XBFZZ		5-11-420-6-7	81337	Slide, Shutter	BEC	EA 2
D-1	23	PAFZZ	7360-01-159-8294	5-11-420-6-8	81337	Shutter	BEC	EA 2
D-1	23A	XDFZZ		*MIL-R-24243/1-B402	81349	Rivet, Blind	BEC	EA 4
D-1	23B	XDFZZ		5-11-2074	81337	Sign, Danger	BEC	EA 1
D-1	24	PAFZZ	5320-00-772-3949	5-11-414-31	81337	Rivet,Solid	BEC	EA 4
D-1	25	XBFZZ		5-11-910-9	81337	Hanger, Lower Hinge	BEC	EA 2
D-1	26	XBFZZ		5-11-910-25	81337	Bar, Fire Unit	BEC	EA 1
D-1	27	PBFZZ		5-11-419-6-29	81337	Rivet, Stay, Lower	BEC	EA 2
D-1	28	PBFZZ	5320-00-010-4127	5-11-419-6-39	81337	Rivet, Stay, Middle	BEC	EA 2
D-1	29	XBFZZ		5-11-420-6-24	81337	Stay, L.H. Upper Door	BEC	EA 1
D-1	29	XBFZZ		5-11-419-6-23	81337	Stay, R.H. Upper Door	BEC	EA 1
D-1	30	XBFZZ		5-11-420-6-25	81337	Stay, Lower R.H. Door	BEC	EA 1
D-1	30	XBFZZ		5-11-419-6-32	81337	Stay, Lower L.H. Door	BEC	EA 1

* For reference only

(1) ILLUSTRATION		(2)	(3)	(4)	(5)	(6)	(7)	(8)	
(A) FIG. NO.	(B) ITEM NO.	SMR CODE	NATIONAL STOCK NUMBER	PART NUMBER	FSCM	DESCRIPTION	U/M	QTY INC IN UNIT	
						USABLE ON CODE			
D-1	31	PAOZZ	5305-00-021-3620	*MS35307-307	96906	Screw, Cap	BEC	EA	2
D-1	31A	PAOZZ	5310-00-933-8121	*MS35338-139	96906	Washer, Lock	BEC	EA	2
D-1	32	PAOFF	7360-00-999-9881	5-11-417-3	81337	Lid Assembly	BEC	EA	1
D-1	33	PBOZZ	5305-00-054-6668	5-11-414-29	81337	Screw, Machine Retainer Hinge	BEC	EA	4
D-1	33A	PBOZZ	5310-00-543-2739	*MS35333-72	96906	Washer, Lock No. 8	BEC	EA	4
D-1	34	PAOZZ		5-11-414-39	81337	Retainer, Hinge	BEC	EA	2
D-1	35	XBFZZ		5-11-417-3-13	81337	Pin, Lid Stay	BEC	EA	1
D-1	36	XBPZZ		5-11-417-3-14	81337	Washer, Flat Lid Stay Pin	BEC	EA	2
D-1	37	XBFZZ		5-11-417-3-15	81337	Washer, Flat Lid Stay Pin	BEC	EA	2
D-1	38	PBFZZ	5320-00-754-0994	5-11-417-3-4	81337	Rivet, Lid Hinge MTG	BEC	EA	8
D-1	39	XBFZZ		5-11-417-3-6	81337	Hinge Assembly	BEC	EA	2
D-1	40	XBFZZ		5-11-418-3-5	81337	Handle-Retainer, Lid	BEC	EA	1
D-1	41	XBFZZ		5-11-418-3-2	81337	Handle, Lid	BEC	EA	1
D-1	42	XBFZZ		5-11-417-3-12	81337	Pin, Lid Stay (Long)	BEC	EA	1
D-1	43	XBFZZ		5-11-417-3-15	81337	Washer, Flat Lid Stay	BEC	EA	2
D-1	44	XBFZZ		5-11-424-36	81337	Stay, Lid	BEC	EA	1
D-1	45	PBOZZ	5315-00-842-3044	5-11-424-14-3	81337	Cotter Pin, Latching	BEC	EA	5
D-1	46	XBOZZ		5-11-425-14-4	81337	Pin, Lifting Handle	BEC	EA	4
D-1	47	PAOZZ	7360-00-999-9885	5-11-424-13-3	81337	Pin, Latching, Upper	BEC	EA	1
D-1	48	PAOZZ	5360-00-926-5331	5-11-425-13-4	81337	Spring, Latch Pin	BEC	EA	1
D-1	49	XBOZZ		5-11-425-13-5	81337	Washer, Flat Latch Pin	BEC	EA	1
D-1	50	PAOZZ	7360-00-999-9884	5-11-425-13-1	81337	Handle, Lifting	BEC	EA	2
D-1	51	PNFZZ	5320-00-772-3949	5-11-414-31	81337	Rivet, Solid	BEC	EA	9
D-1	52	XNFZZ		5-11-425-13-8	81337	Bracket: Left And Right Rear, Lifting Handle	BEC	EA	2
D-1	53	XBFZZ		5-11-419-6-26	81337	Bracket, Stay, Door	BEC	EA	2
D-1	54	PNFZZ	5320-00-068-2279	5-11-414-20	81337	Rivet, Lifting	BEC	EA	10
D-1	55	XBFZZ		5-11-425-13-2	81337	Bracket: Right Front Lifting	BEC	EA	1
D-1	55	XNFZZ		5-11-425-14-2	81337	Bracket: Left Front Lifting	BEC	EA	1
D-1	56	XNFZZ		5-11-414-22	81337	Washer, Flat, Latch Pin	BEC	EA	1
D-1	57	PBFZZ	7360-00-999-3911	5-11-424-15	81337	Pin, Latch	BEC	EA	1
D-1	58	XNFZZ		5-11-424-17	81337	Connector-Male	BEC	EA	1
D-1	59	XNFZZ		5-11-424-16	81337	Connector-Female	BEC	EA	1

*For reference only

TM 10-7360-204-13&P

(1) ILLUSTRATION		(2) SMR CODE	(3) NATIONAL STOCK NUMBER	(4) PART NUMBER	(5) FSCM	(6) DESCRIPTION USABLE ON CODE		(7) U/M	(8) QTY INC IN UNIT
(A) FIG NO.	(B) ITEM NO.								
D-1	60	XBFZZ		5-11-416-1-15	81337	BLOCK, BEARING	BEC	EA	2
D-1	61	XBFZZ		5-11-416-1-16	81337	BEARING, ROLLER	BEC	EA	2
D-1	62	XBFZZ		5-11-416-1-17	81337	ROLLER	BEC	EA	2
D-1	63	XBFZZ		5-11-416-1-19	81337	SHAFT, ROLLER	BEC	EA	1
D-1	64	XBFZZ		5-11-416-1-22	81337	RAIL, PAN, LEFT HAND	BEC	EA	1
D-1	65	XBFZZ		5-11-416-1-23	81337	RAIL, PAN, RIGHT HAND	BEC	EA	1
D-1	66	XBFZZ		5-11-416-1-24	81337	SPACER, RACK	BEC	EA	4
D-1	67	XBFZZ		5-11-416-1-7	81337	STAPLE, DOOR LATCH	BEC	EA	2
D-1	68	XBFZZ		5-11-416-1-21	81337	RAIL, UPPER, RIGHT	BEC	EA	1
D-1	69	XBFZZ		5-11-416-1-20	81337	RAIL, UPPER, LEFT	BEC	EA	1
D-1	69	XBFZZ		5-11-416-1-14	81337	RAIL, CRADLE, RIGHT	BEC	EA	1
D-1	69	XBFZZ		5-11-416-1-13	81337	RAIL, CRADLE, LEFT	BEC	EA	1
D-1	69	XBFZZ		5-11-416-1-12	81337	RAIL, BOTT., RIGHT	BEC	EA	1
D-1	69	XBFZZ		5-11-416-1-11	81337	RAIL, BOTT., LEFT	BEC	EA	1

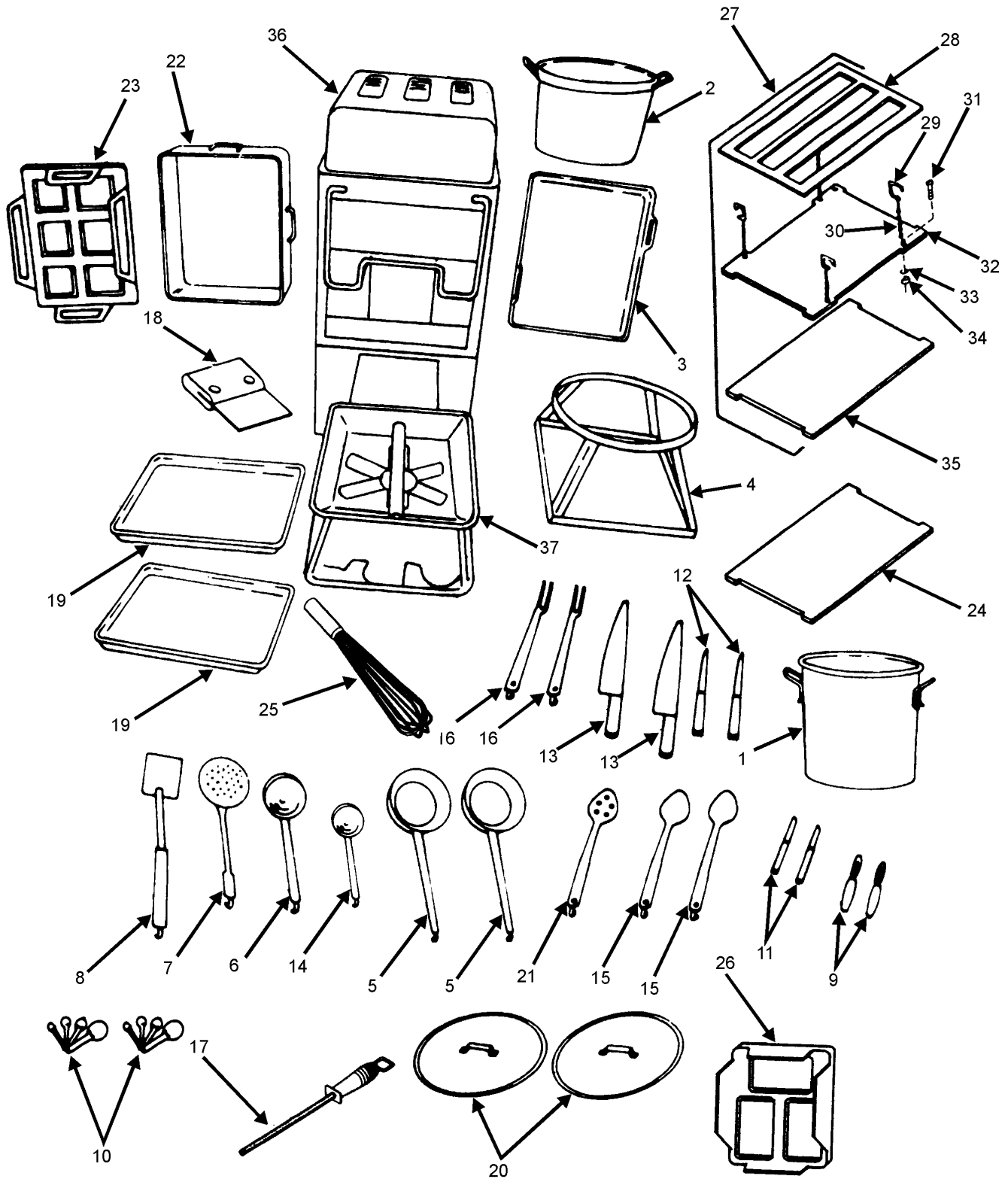

Figure D-2. Field Range Outfit

(1)		(2)	(3)	(4)	(5)	(6)		(8)	(9)
ILLUSTRATION		SMR CODE	NATIONAL STOCK NUMBER	PART NUMBER	FSCM	DESCRIPTION	U/M	QTY INC IN UNIT	
(A) FIG NO.	(B) ITEM NO.								USABLE ON CODE
D-2	1	PAOZZ	7330-00-292-2307	2-09-120	81349	GROUP 02-CABINET COMPONENTS POT, COOKING 15 GAL	BEC	EA	1
D-2	2	PAOZZ	7330-00-292-2306	2-09-35	81349	POT, COOKING 10 GAL	BEC	EA	1
D-2	3	PAOZZ	7330-00-263-8516	A-A-52201	81349	COVER, BAKING AND ROASTING PAN	BEC	EA	1
D-2	4	PAOZZ	7330-00-379-2495	5-11-71-34	81337	CRADLE, COOK POT	BEC	EA	1
D-2	5	PAOZZ	7330-00-272-2489	A-A-1752	81348	DIPPER, KITCHEN	BEC	EA	2
D-2	6	PAOZZ	7330-00-248-1153	A-A-1956 SIZE 3	81348	LADLE, KITCHEN	BEC	EA	1
D-2	7	PAOZZ	7330-00-680-2635	A-A-1072	58536	SKIMMER, KITCHEN	BEC	EA	1
D-2	8	PAOZZ	7330-00-634-1995	A-A-1640 TYPE 1 STYLE A	81348	TURNER, FOOD	BEC	EA	1
D-2	9	PAOZZ	7330-00-238-8316	A-A-1953	81349	PEELER, POTATO, HAND	BEC	EA	2
D-2	10	PAOZZ	7330-00-272-7876	A-A-1954	81349	MEASURING SET, SPOON (CRS)	BEC	EA	2
D-2	11	PAOZZ	7340-00-488-7939	A-A-2733	81348	KNIFE, PARING	BEC	EA	2
D-2	12	PAOZZ	7340-00-197-1271	A-A-2733	81348	KNIFE, BONING	BEC	EA	2
D-2	13	PAOZZ	7340-00-488-7950	A-A-2733	81348	KNIFE, COOK'S	BEC	EA	2
D-2	14	PAOZZ	7330-00-680-0865	A-A-1956 SIZE 2	81348	LADLE	BEC	EA	1
D-2	15	PAOZZ	7340-00-223-7800	A-A-52204 TYPE II SIZE 2	81349	SPOONS, BASTING	BEC	EA	2
D-2	16	PAOZZ	7340-00-223-7791	A-A-52204 TYPE I SIZE 1	81349	FORK-FOOD	BEC	EA	2
D-2	17		7330-00-550-7592	A-A-2733 TYPE X	81348	BUTCHER'S STEEL		EA	1
D-2	18		7330-00-205-1950	A-A-52068	81349	SCRAPER, BAKER'S		EA	1
D-2	19	PAOZZ	7330-00-272-2589		81349	PAN-RECTANGULAR	BEC	EA	2
D-2	20	PAOZZ	7330-00-250-6300	2-09-35	81349	COVER, COOK POT	BEC	EA	2
D-2	21		7340-00-255-0702	A-A-1082 TYPE II, SIZE 2		SPOON, FOOD SERVICE (STRAINING)		EA	1
D-2	22	PAOZZ	7330-00-485-7376	A-A-52201	81349	PAN, BAKING AND ROASTING, DEEP	BEC	EA	1
D-2	23	PAOZZ	7330-00-148-7173	A-A-52201	81349	WARMER, ADAPTER (OPTIONAL)	BEC	EA	1
D-2	24			5-11-353-7	81337	RACK, BOTTOM	BZZ	EA	1
D-2	25		7330-00-815-1458	A-A-394	81348	WHIP, EGG	BZZ	EA	1
D-2	26					WARMER, ADAPTER		EA	1
D-2	27		7360-00-106-5965	5-11-353	81337	RACK SET, BAKE		EA	1
D-2	28			5-11-353-6	81337	RACK, TOP	BZZ	EA	1
D-2	29			5-11-353-5	81337	HOOK, CHAIN, MIDDLE RACK	BZZ	EA	4
D-2	30			5-11-353-1	81337	MIDDLE RACK MTG	BZZ	EA	4
D-2	31			5-11-353-3	81337	SCREW, MACHINE	BZZ	EA	4
D-2	32			5-11-353-8	81337	RACK, MIDDLE	BZZ	EA	1
D-2	33			5-11-353-2	81337	WASHER, LOCK	BZZ	EA	4
D-2	34			5-11-353-4	81337	NUT, PLAIN HEXAGON	BZZ	EA	4
D-2	35			5-11-353-7	81337	RACK, BOTTOM	BZZ	EA	1
D-2	36	PAOZZ	7330-00-702-1719	5-11-414	81349	CABINET, GASOLINE FIELD, RANGE OUTFIT	BEC	EA	1
D-2	37	PAOZZ	7310-00-842-9247	5-11-1225-1	81337	BURNER UNIT M2 AND BURNER UNIT M2A, NSN 7310-01-017-1285	BEC	EA	1

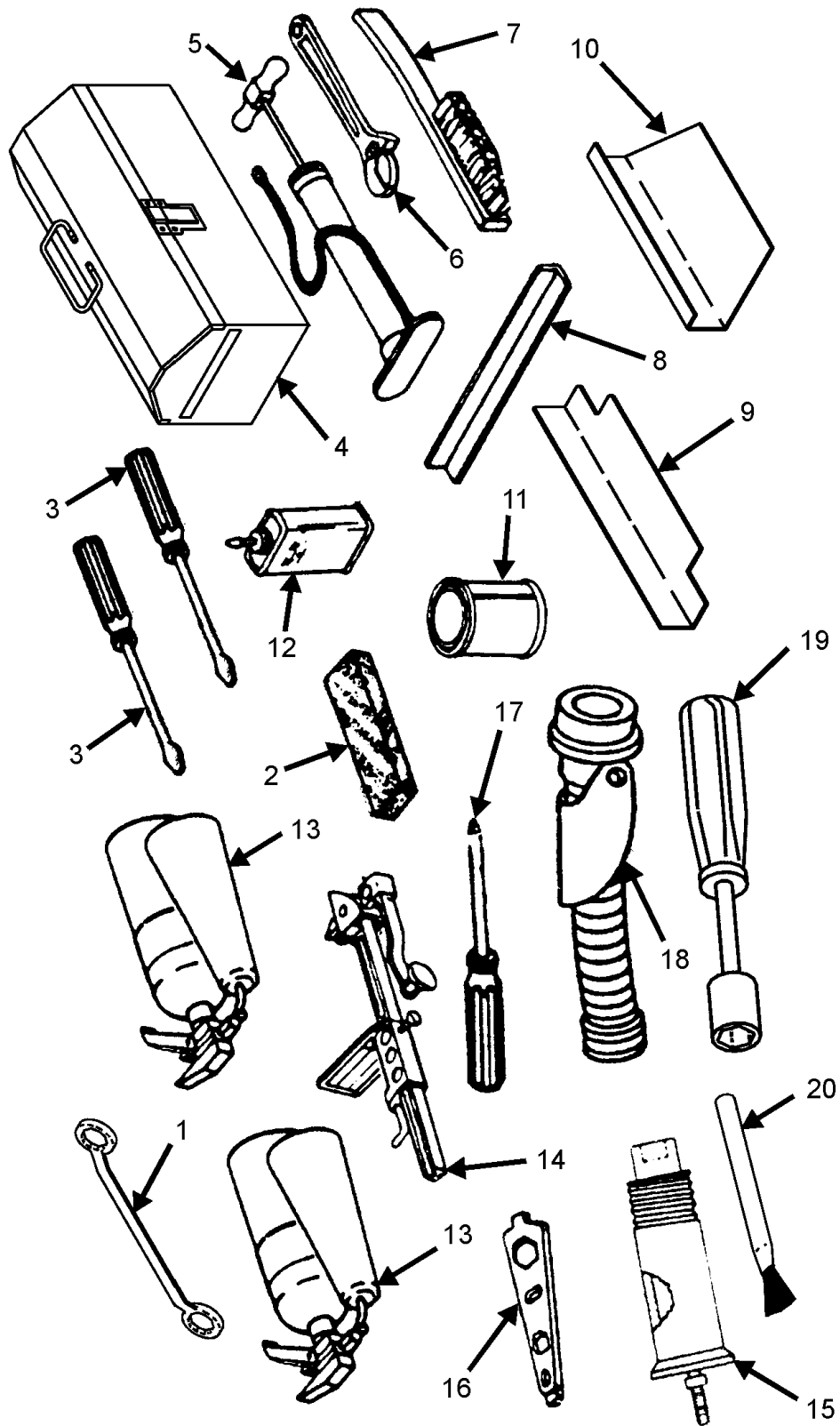

Figure D-3 Accessory Items

(1) ILLUSTRATION		(2) SMR CODE	(3) NATIONAL STOCK NUMBER	(4) PART NUMBER	(5) FSCM	(6) DESCRIPTION	(7) U/M	(8) QTY INC IN UNIT
(A) FIG NO.	(B) ITEM NO.					USABLE ON CODE		
						Group 03 – ACCESSORY ITEMS		
D-3	1		5120-00-224-3154	ANSI B107.6		BOX, WRENCH	BEC	EA 1
D-3	2	PAOZZ	5345-00-198-8040	A-A-3068/3	81348	STONE, SHARPENING	BEC	EA 1
D-3	3	PAOZZ	5120-00-222-8852	ANSI B107.15	96906	SCREWDRIVER, FLAT TIP	BEC	EA 2
D-3	4			5-11-2075-1	81337	CHEST, TOOL	BEC	EA 1
D-3	5	PAOZZ	4320-00-852-9036	A-A-2888	81348	PUMP, INFLATING	BEC	EA 1
D-3	6	PAOZZ	5120-00-240-5328	A-A-2344	81348	WRENCH, ADJUSTING	BEC	EA 1
D-3	7	PAOZZ	7920-00-291-5815	A-A-3118	81348	BRUSH, WIRE	BEC	EA 1
D-3	8	PAOZZ	5120-00-379-2490	5-11-907	81349	CLEANER, BURNER, SLOT	BEC	EA 1
D-3	9	PAOZZ	7360-00-402-2403	5-11-964	81349	PROTECTOR, ARM, GASOL	BEC	EA 1
D-3	10	PAOZZ	7360-00-402-4495	5-11-964	81349	PROTECTOR, ARM, GASOL	BEC	EA 1
D-3	11	PAOZZ	8030-00-087-8630	*MIL-T-83483	81349	ANTISEIZE, COMPOUND	BEC	EA 1
D-3	12	PAOZZ	9150-00-252-6173	*VV-L-800	81348	LUBRICATING OIL, GEN	BEC	EA 1
D-3	13	PAOZZ	4210-00-270-4512	UL154	81348	EXTINGUISHER, FIRE	BEC	EA 2
D-3	14	PAOZZ	7330-00-205-3151	A-A-52206	81348	OPENER, CAN	BEC	EA 1
D-3	15	PAOZZ	7310-00-999-2552	5-11-1232	81317	GENERATOR, PREHEATER	BEC	EA 1
D-3	16	PAOZZ	5120-00-303-7737	PC5-10 2-9-108	81337	WRENCH, ASSEMBLY	BEC	EA 1
D-3	17	PAOZZ	5120-00-234-8913	ANSI B107.15	96906	SCREWDRIVER, CROSS TIPBEC		EA 1
D-3	18	PAOZZ	7240-00-177-6154		81349	SPOUT, CAN, FLEXIBLE	BEC	EA 1
D-3	19	PAOZZ	5120-00-770-0030	*GGG-W-657 TYPE II	81348	NUT DRIVER 7/16 INCH, USED ONLY WITH THE MODERN BURNER UNIT (MBU)	BEC	EA 1
D-3	20	PAOZZ	7920-00-514-2417	A-A-289 TYPE 2	81348	BRUSH, CLEANING, USED ONLY WITH THE MODERN BURNER UNIT (MBU)	BEC	EA 1

* for reference only

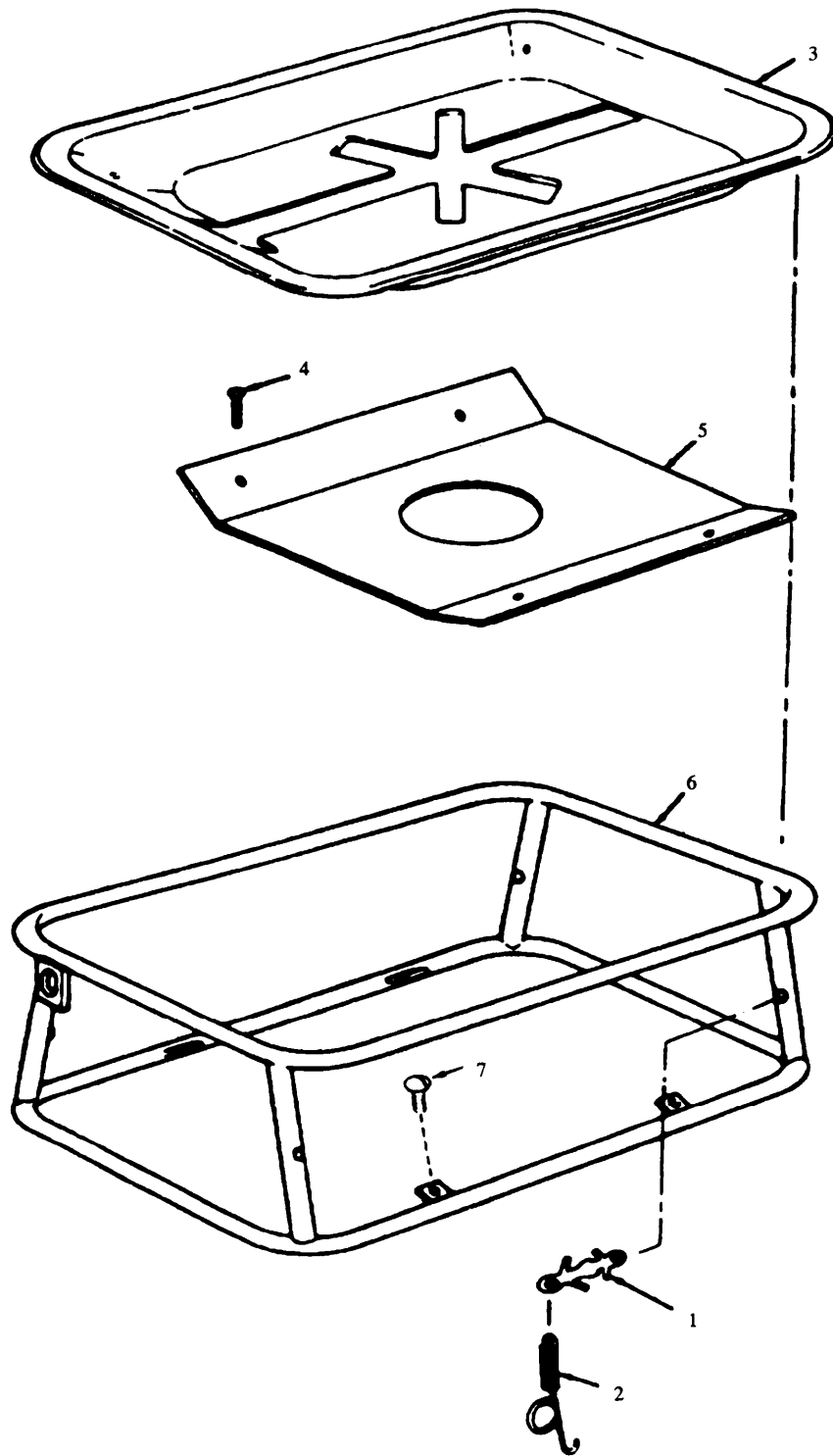

Figure D-4 Burner Unit (Sheet 1 of 3)

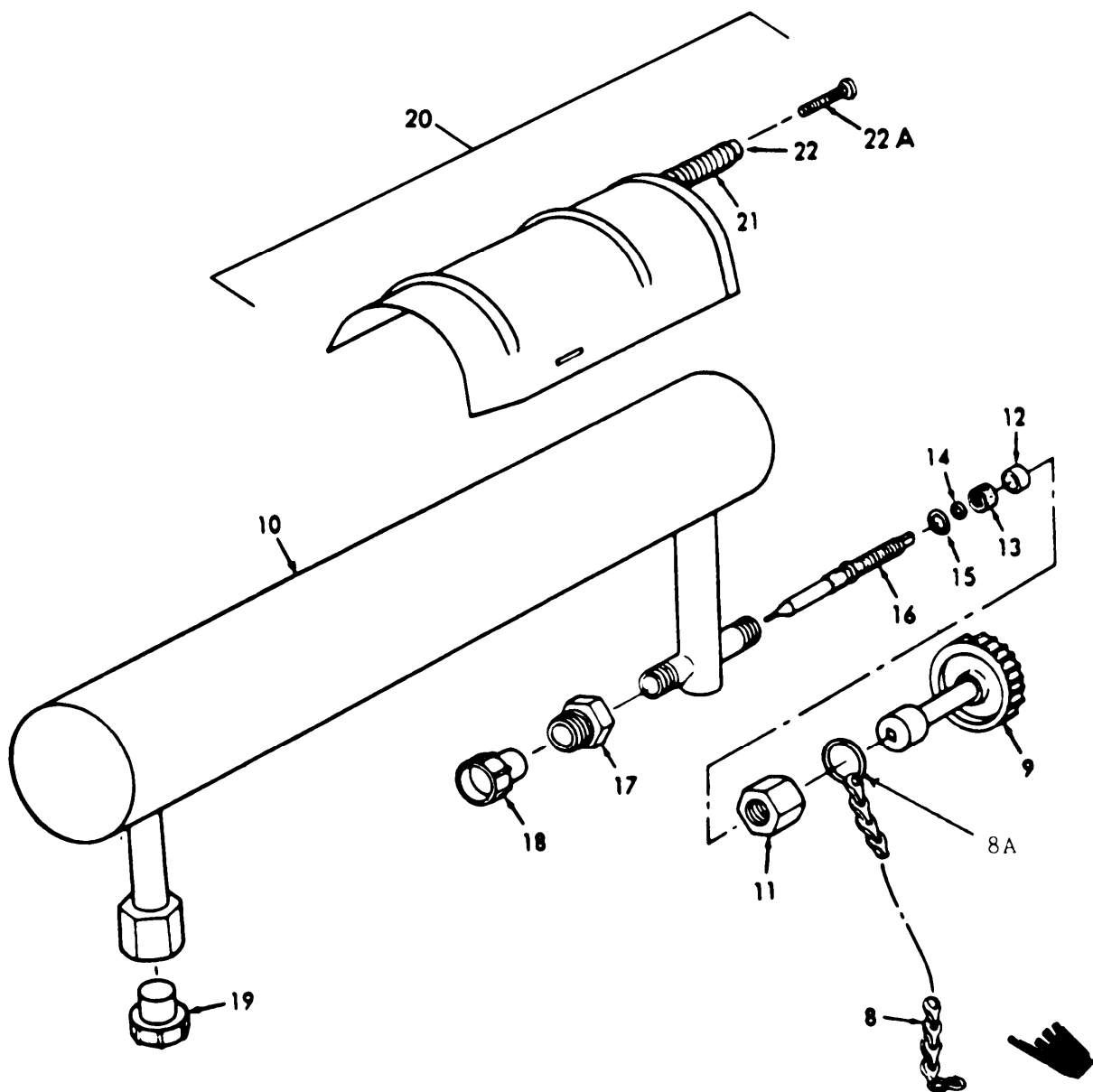

Figure D4. Burner Unit (Sheet 2 of 3)

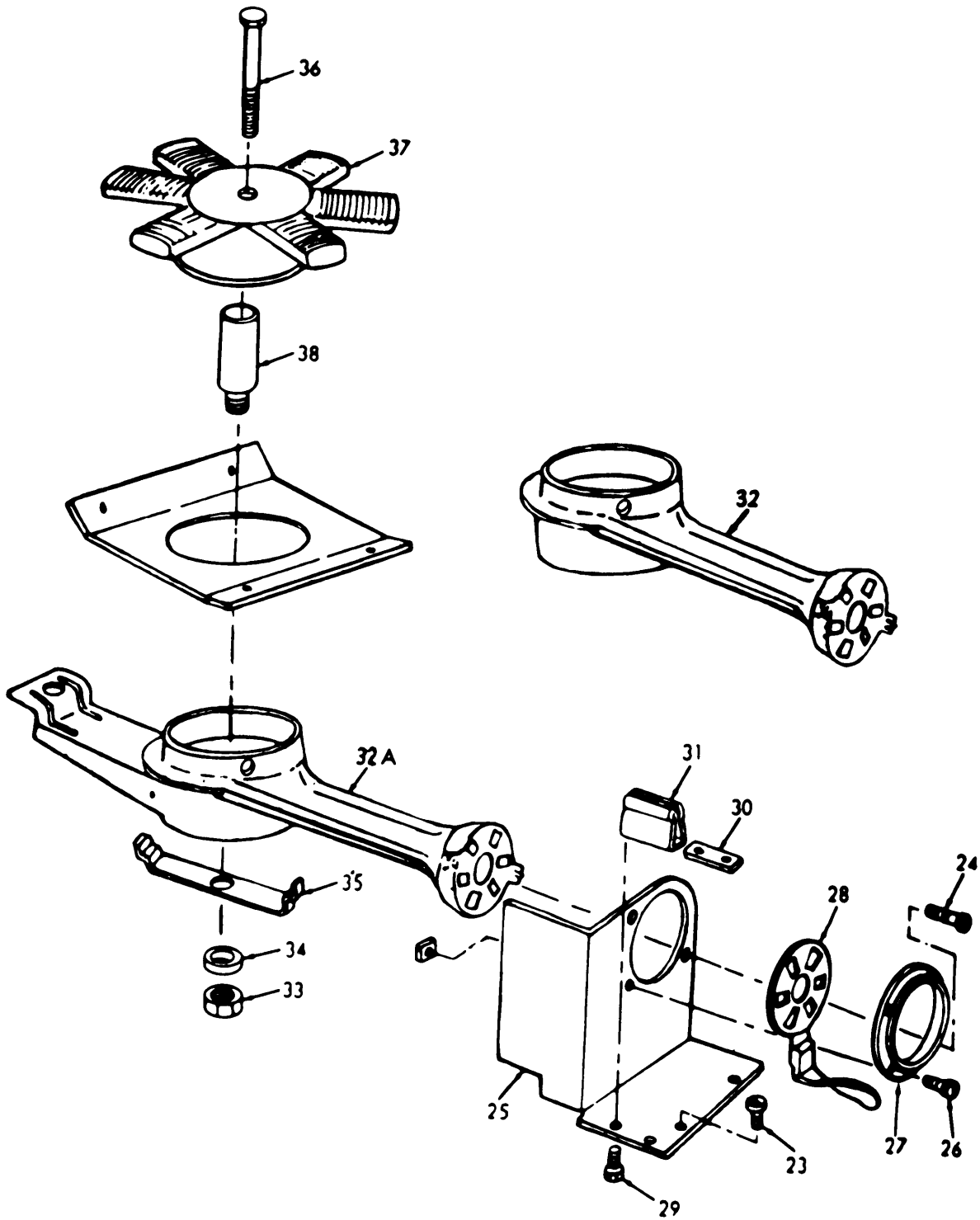

Figure D-4. Burner Unit (Sheet 3 of 3)

(1) ILLUSTRATION		(2) SMR CODE	(3) NATIONAL STOCK NUMBER	(4) PART NUMBER	(5) FSCM	(6) DESCRIPTION	(7) U/M	(8) QTY INC IN UNIT
(A) FIG NO.	(B) ITEM NO.					USABLE ON CODE		
		PAOFF	7310-01-017-1285	5-11-1225-1	81337	GROUP 04-ACCESSORY ITEMS GROUP 05-BURNER ASSEMBLY Modern Burner Unit (Not Illustrated). Refer to TM 10-7360-281-13&P for Parts Breakdown		
D4		PAOFF	7310-01-017-1285	5-11-1225-1	81337	M-2 Burner Unit	BEC	EA 1
D4	1	PAOZZ	7310-00-348-9189	5-11-1225-26	81337	Clip, Tinnerman Dart	BED	EA 6
D4	2	PAOZZ	7310-00-999-2505	5-11-1243-15	81337	Spring Hook	BED	EA 4
D4	3	PAOZZ	7310-00-999-2502	5-11-1243-12	81337	Shield Top Assembly	BED	EA 1
D4	4	PAOZZ	5305-00-057-9610	*MS51861-27	96906	Screw, Self-Tapping	BED	EA 4
D4	5	PAOZZ	7310-00-999-2482	5-11-1228-11	81337	Shield, Bottom	BED	EA 1
D4	6	PAOZZ	7310-00-999-2496	5-11-1226-2	81337	Frame Assembly	BED	EA 1
D4	7	PBOZZ	5305-00-082-6721	5-11-1225-18	81337	Screw, Machine	BED	EA 4
D4	7					Screw Machine W/Shoulder (deleted)		
D4	8	PAOZZ	4010-00-228-9930	*RR-C271TYPE II CLASS 3	81348	Chain, Sash	BED	EA 2
D4	8A	PAOZZ	5340-00-933-3596	5-11-1236-7-3	81337	Ring Key	BED	EA 1
D4	9	PAOZZ	5355-00-999-2494	5-11-1236-7	81337	Knob,Flame Valve	BED	EA 1
D4	10	PAOOO	7310-00-999-2495	5-11-1238-9	81337	Generator Assembly	BED	EA 3
D4	11	PAOZZ	7310-00-999-2480	5-11-1239-9-16	81337	Nut Packing	BED	EA 1
D4	12	PAOZZ	7310-00-999-2474	5-11-1235-5-41	81337	Gland, Packing	BED	EA 1
D4	13	KDOZZ		5-11-1235-9-23	81338	Packing, Valve StemComponent Of Kit, NSN 7310-00-302-7941, P/N BMC 6256	BED	EA 1
D4	14	XBOZZ		5-11-1235-9-15	81337	Retainer Ring	BED	EA 1
D4	15	PAOZZ	7310-00-999-2489	5-11-1235-9-14	81337	Clamp Ring	BED	EA 1
D4	16	KFOZZ		5-11-1239-9-13	81337	Valve Stem, Component Of Kit, NSN 7310-00-302-7941, P/N BMC 6256	BED	EA 1
D4	17	KFOZZ		5-11-1239-9-17	81337	Nut, Orifice,Componemt Of Kit, NSN 7310-00-302-7941, P/N BMC 6256	BED	EA 1
D4	18	XBOZZ		5-11-1238-9-21	81337	Cap	BED	EA 1
D4	19	XBOZZ		5-11-1238-9-20	81337	Plug	BED	EA 1
D4	20	PAOZZ	7310-00-999-2511	5-11-1244-23	81337	Shield Assy, Preheater	BED	EA 1
D4	21	XAOZZ	7310-00-999-2512	5-11-1244-23-3	81337	Handle, Coil	BED	EA 1
D4	22	XAOZZ	7310-00-999-2513	5-11-1244-23-4	81337	Adapter, Coil	BED	EA 1
D4	22A	XAOFF	5305-00-069-5122	5-11-1244-23-5	81337	Screw Mach, RD HD NO 8-32 UNC-2A X 2 3/8	BED	EA 1

*For reference only

TM 10-7360-204-13&P

(1) ILLUSTRATION		(2) SMR CODE	(3) NATIONAL STOCK NUMBER	(4) PART NUMBER	(5) FSCM	(6) DESCRIPTION USABLE ON CODE	(7) U/M	(8) QTY INC IN UNIT	
(A) FIGURE NO.	(B) ITEM NO.								
D4	23	PBOZZ	5305-00-082-6721	5-11-1225-18	81337	SCREW, MACHINE	BED	EA	2
D4	24	PBOZZ	5305-00-760-5502	5-11-1225-16	81337	SCREW, MACHINE	BED	EA	2
D4		PAOZZ	7310-00-999-2514	5-11-1236-6	81337	SHUTTER ASSEMBLY AIR	BED	EA	1
D4	25	PAOZZ	7310-00-999-2490	5-11-1236-6-1	81337	HOLDER, SHUTTER	BED	EA	1
D4	26	PBOZZ	5305-00-984-6206	5-11-1236-6-8	81337	SCREW, MACHINE	BED	EA	2
D4	27	PAOZZ	7310-00-999-2491	5-11-1236-6-2	81337	RING, SHUTTER	BED	EA	1
D4	28	PAOZZ	7310-00-999-2492	5-11-1236-6-3	81337	SHUTTER	BED	EA	1
D4	29	PBOZZ	5305-00-054-6666	5-11-1236-6-7	81337	SCREW, CAP, HEXAGON	BED	EA	2
D4	30	PAOZZ	7310-00-999-2562	5-11-1236-6-5	81337	NUT	BED	EA	2
D4	31	PAOZZ	7310-00-999-2493	5-11-1236-6-4	81337	HOLDER, FLAME VALVE	BED	EA	1
D4	32	ZBOZZ	7310-01-016-2241	5-11-1240-10	81337	MIXING CHAMBER (REPLACED BY NSN 7310-01-062-7074)	BED	EA	1
D4	32A	ZBOZZ	7310-01-062-7074	5-11-1240-30	81337	MIXING CHAMBER (REPLACED BY NSN 7310-01-016-2241)	BED	EA	1
D4	33	PBOZZ	5310-00-638-3899	5-11-1240-10-8	81337	NUT, PLAIN HEXAGON	BED	EA	1
D4	34	PBOZZ	5310-00-637-9541	5-11-1240-30-7	81337	WASHER, LOCK	BED	EA	1
D4	35	PAOZZ	7310-00-999-2499	5-11-1241-10-9	81337	HOLDER, PREHEATER	BED	EA	1
D4	36	PBOZZ	7310-00-999-2506	5-11-1225-17	81337	BOLT,BURNER	BED	EA	1
D4	37	PBOZZ	7310-00-999-2478	5-11-1237-8	81337	BURNER	BED	EA	1
D4	38	PAOZZ	7310-00-999-2498	5-11-1241-10-10	81337	BUSHING	BED	EA	1

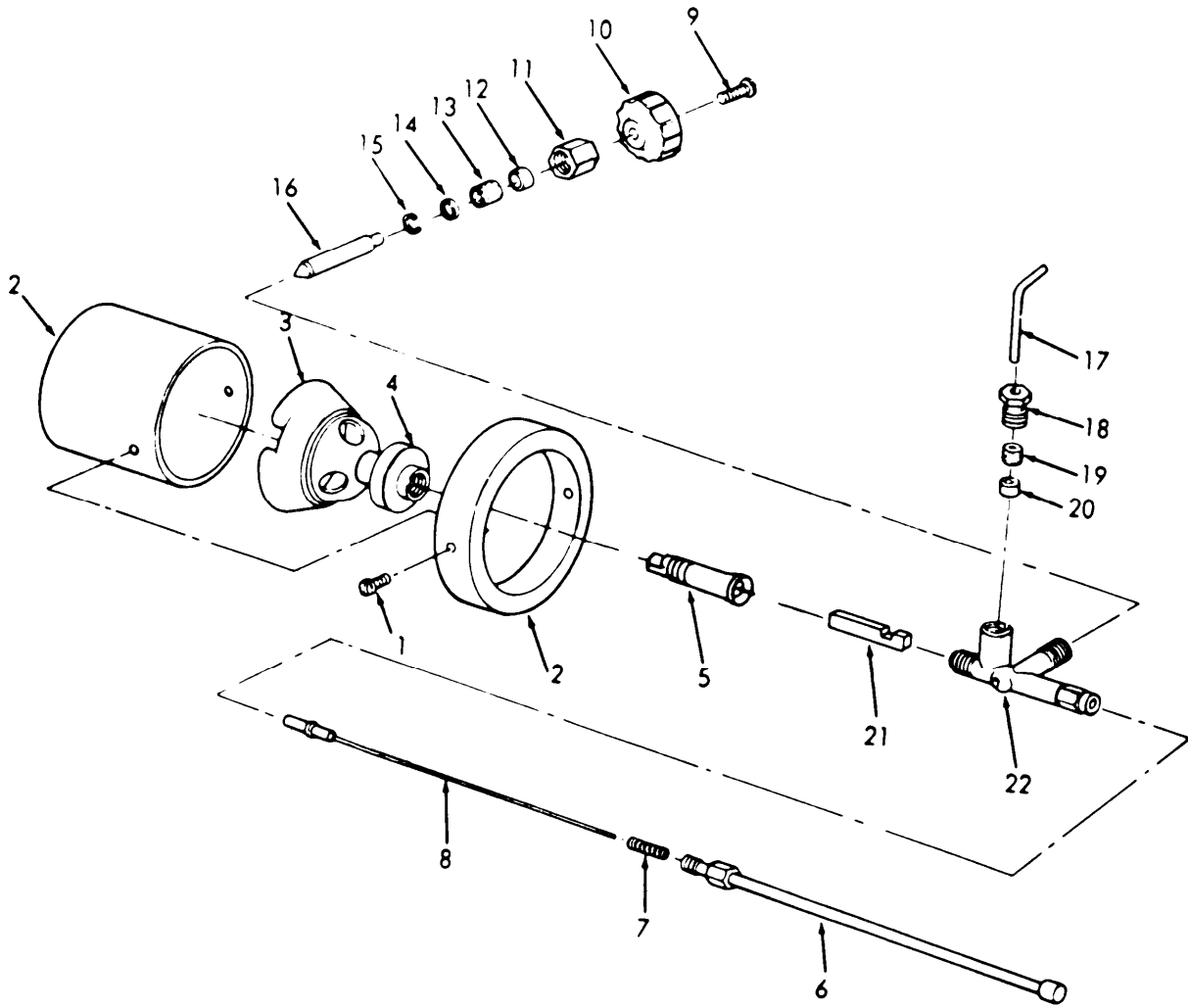

Figure D-5. Preheater Assembly

(1) ILLUSTRATION		(2) SMR CODE	(3) NATIONAL STOCK NUMBER	(4) PART NUMBER	(5) FSCM	(6) DESCRIPTION	(7) U/M	(8) QTY INC IN UNIT
(A) FIG NO.	(B) ITEM NO.					USABLE ON CODE		
D5		PAOOO	7310-00-999-2549	5-11-1230-5	81337	PREHEATER ASSEMBLY	EA	1
D5	1	XAOZZ		* MS51861-12C	96906	SCREW, SELF-TAPPING BED	EA	2
D5	2	XAOZZ		5-11-1231-5-7	81337	CUP, DRIP BED	EA	1
D5	3	XAOZZ		5-11-1231-5-1	81337	PREHEATER HEAD ASSEMBLY BED	EA	1
D5	4	XAOZZ		5-11-1232-5-48	81337	CUP FUEL ASSEMBLY BED	EA	1
D5	5	PAOZZ	7310-00-999-2552	5-11-1232-5-10	81337	PREHEATER GENERATOR ASSEMBLY BED	EA	1
D5	6	XAOZZ		5-11-1233-5-20	81337	AIR, FUEL FEED BED	EA	1
D5	7	XAOZZ		5-11-1233-5-19	81337	SPRING BED	RA	1
D5	8	XAOZZ		5-11-1233-5-27	81337	NEEDLE ASSEMBLY BED	EA	1
D5	9	XAOZZ		5-11-1234-5-38	81337	SCREW, MACHINE BED	EA	1
D5	10	XAOZZ		5-11-1232-5-45	81337	KNOB ASSEMBLY, VALVE BED	EA	1
D5	11	XAOZZ		5-11-1235-5-37	81337	NUT, PACKING, VALVE BED	EA	1
D5	12	XAOZZ		5-11-1235-5-44	81337	PACKING, VALVE STEM BED	EA	1
D5	13	XAOZZ		5-11-1235-5-41	81337	GLAND, PACKING: V.S. BED	EA	1
D5	14	XAOZZ		5-11-1235-5-40	81337	RING, RETAINER BED	EA	1
D5	15	XAOZZ	7310-00-999-2489	5-11-1235-5-34	81337	RING, CLAMP BED	EA	1
D5	16	XAOZZ		5-11-1235-5-33	81337	STEM BED	EA	1
D5	17	XAOZZ		5-11-1235-5-35	81337	STEM-CLEANER TIP BED	EA	1
D5	18	XAOZZ		5-11-1235-5-36	81337	NUT, PACKING BED	EA	1
D5	19	XAOZZ		5-11-1235-5-43	81337	PACKING, CLEANER TIP BED	EA	1
D5	20	XAOZZ		5-11-1235-5-42	81337	GLAND, PACKING BED	EA	1
D5	21	XAOZZ		5-11-1235-5-32	81337	BLOCK-ECCENTRIC BED	EA	1
D5	22	XAOZZ		5-11-1234PC5-31	81337	BODY, VALVE BED	EA	1

* For reference only

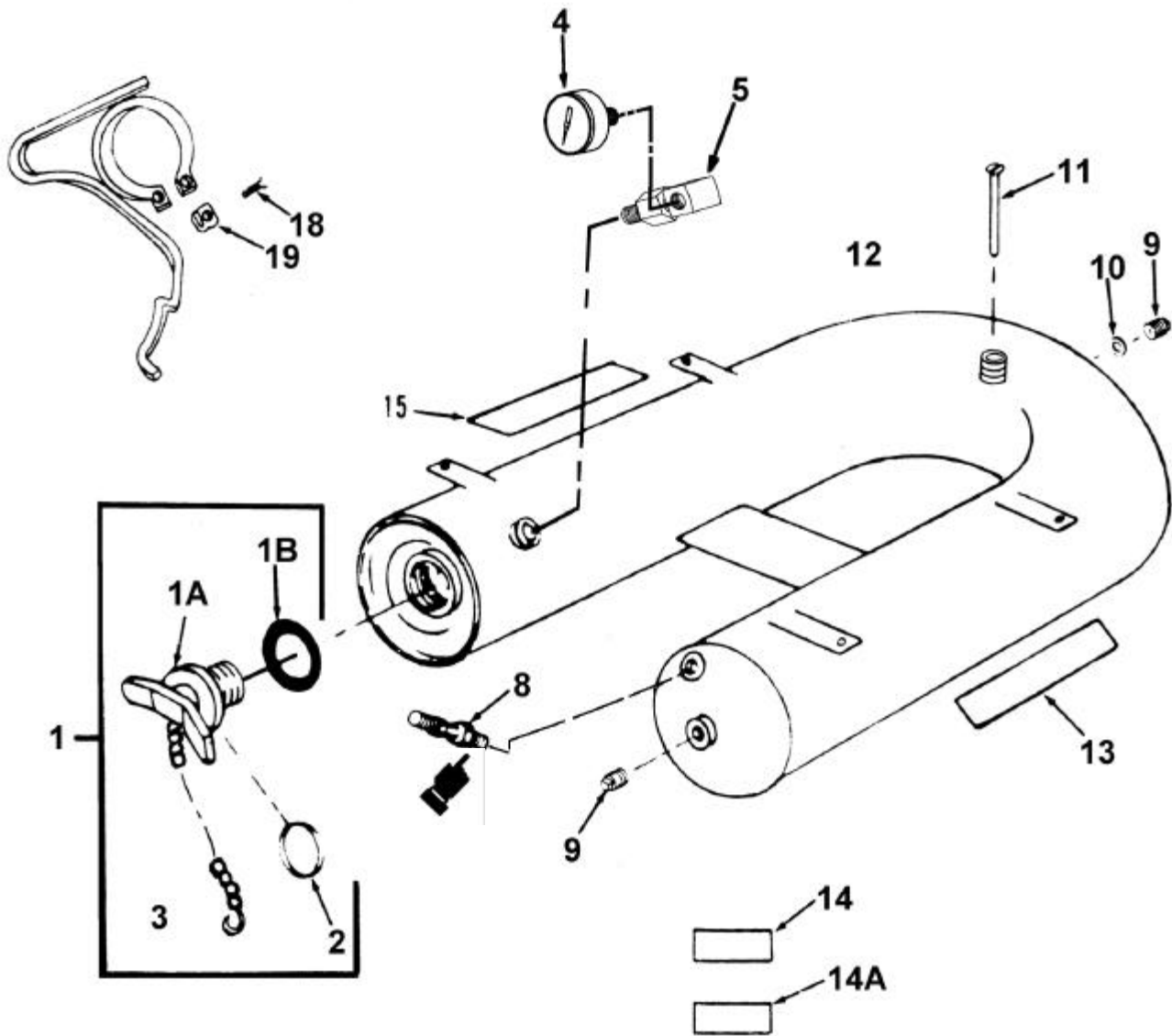

Figure D-6. Fuel Tank Assembly.

(1) ILLUSTRATION		(2) SMR CODE	(3) NATIONAL STOCK NUMBER	(4) PART NUMBER	(5) FSCM	(6) DESCRIPTION	(7) U/M	(8) QTY INC IN UNIT
(A) FIG NO.	(B) ITEM NO.					USABLE ON CODE		
D-6	1	PAOOO	7310-01-280-0458	5-11-1229-4A	81337	Cap, Filler Opening	BED	EA 1
D-6	1A	XAOZZ		5-11-1229-4-1-3	81337	• Filler Cap W/Handle	BED	EA 1
D-6	1B	PAOZZ	5330-01-362-3428	5-11-2072	81337	• Gasket	BED	EA 1
D-6	2	XBOZZ		5-11-1229-4-4	81337	• Ring, Key: 1 1/2In.	BED	EA 1
D-6	3	PAOZZ	4110-00-171-4512	*RR-C-271 TYPE II CL3	81348	• Chain, Weldless, No. 8, 18 Links Long	BED	FT 1
D-6	4	PAOZZ	6685-00-999-2503	5-11-1242-13	81337	Gage, Air Pressure	BED	EA 1
D-6	5	PAOZZ		5-11-2071-14	81337	Elbow, 45 Degree, 1/8 Inch	BED	EA 1
D-6	6			ITEM DELETED				
D-6	7			ITEM DELETED				
D-6	8	PAOOO	7310-01-449-9955	5-11-1229-25	81337	Air Valve Assembly	BED	EA 1
D-6	9	PAOZZ	7310-00-999-2547	5-11-1227-3-11	81337	Plug, Drain, Fuel	BED	EA 1
D-6	10	PAOZZ	5310-00-275-6604	5-11-1227-29-10	81337	Washer, Drain Plug	BED	EA 1
D-6	11	PAOZZ	7310-00-999-2504	5-11-1242-14	81337	Feed Tube Assembly	BED	EA 1
D-6	12	PAOZZ	7310-01-016-2242	5-11-1227-29	81337	U-Tank Assembly (Replacement For NSN 7310-00-879-1740)	BED	EA 1
D-6	13	PAOZZ	7310-00-999-2510	5-11-1227-21	81337	Maintenance, Decal	BED	EA 1
D-6	13			5-11-1235-9-23	81337	Packing Part Of Kit P/N BMC 6256	BED	EA 1
D-6	14	PAOZZ	7930-00-003-8582	5-11-1242-20	81337	Caution, Decal	BED	EA 1
D-6	14A	PAOZZ	7690-01-082-2865	5-11-1242-28	81337	Caution, Decal	BED	EA 1
D-6	15	PAOZZ	7690-00-999-2509	5-11-1227-22	81337	Operation, Decal	BED	EA 1
D-4	16			5-11-1239- 9-13	81337	Valve Stem, Part Of Kit PN BMC 6256		EA 1
D-4	17			5-11-1239-9-17	81337	Orifice Nut Assembly Part Of Kit P/N BMC 6256		EA 1
D-6	18	PBOZZ	5305-00-984-6211	*MS35206-264	96906	Screw Machine 10-24, Panhead	BED	EA 1
D-6	19	PAOZZ	5310-00-999-2563	5-11-1228PC3-16	81337	Nut, U Type: 10-24 THD Size	BED	EA 4
D-4		PAOZZ	7310-00-302-7941	BMC6256	18895	Repair Kit Generator Valve	BED	EA 1
						Consists Of:		
						Packing	(1) D6-13	
						Valve Stem	(1) D6-16	
						Orifice Nut Assembly	(1) D6-17	

* For reference only

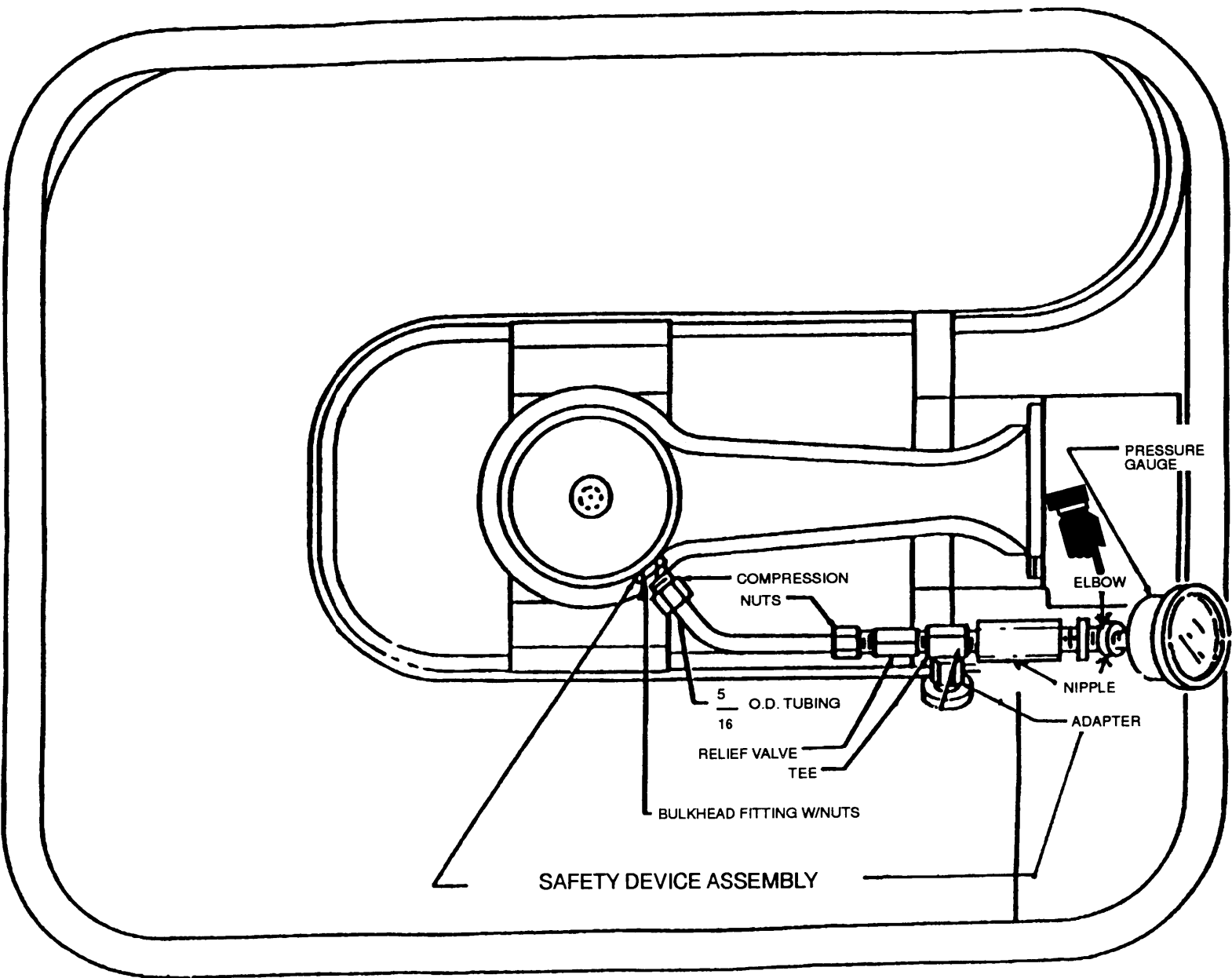

Figure D-7. Safety Device Assembly

(1) ILLUSTRATION		(2) SMR CODE	(3) NATIONAL STOCK NUMBER	(4) PART NUMBER	(5) FSCM	(6) DESCRIPTION USABLE ON CODE	(7) U/M	(8) QTY INC IN UNIT
(A) FIG NO.	(B) ITEM NO.							
D-7	1	PAOZZ	7360-01-343-9014	5-11-2071	81337	SAFETY DEVICE ASSEMBLY (AVAILABLE IN KIT FORM ONLY) BED	EA	1

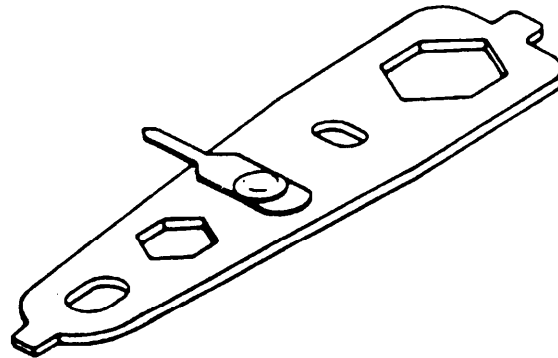

Figure D-8. Special Wrench

(1) ILLUSTRATION		(2) SMR CODE	(3) NATIONAL STOCK NUMBER	(4) PART NUMBER	(5) FSCM	(6) DESCRIPTION	(7) U/M	(8) QTY INC IN UNIT	
(A) FIG NO.	(B) ITEM NO.					USABLE ON CODE			
D-8	1	PAOZZ	5120-00-303-7737	2-9-108	81337	Section IV – Special Tool List Group 01 - SPECIAL TOOL WRENCH, ASSEMBLY	BZZ	EA	1

SECTION IV INDEX - NATIONAL STOCK NUMBER TO FIGURE AND ITEM NUMBER

STOCK NUMBER	FIGURE NO.	ITEM NO.	STOCK NUMBER	FIGURE NO.	ITEM NO.
4010-00-228-9930	D-4	8	7310-00-999-2502	D-4	3
4110-00-171-4512	D-6	3	7310-00-999-2504	D-6	11
4210-00-270-4512	D-3	13	7310-00-999-2505	D-4	2
4320-00-069-1808	D-1	1	7310-00-999-2506	D-4	36
4320-00-852-9036	D-3	5	7310-00-999-2510	D-6	13
5120-00-222-8852	D-3	3	7310-00-999-2511	D-4	20
5120-00-224-3154	D-3	1	7310-00-999-2512	D-4	21
5120-00-234-8913	D-3	17	7310-00-999-2513	D-4	22
5120-00-240-5328	D-3	6	7310-00-999-2547	D-6	9
5120-00-303-7737	D-3 & D-8	16 & 1	7310-00-999-2549	D-5	
5120-00-379-2490	D-3	8	7310-00-999-2552	D-3	15
5120-00-770-0030	D-3	19	7310-00-999-2552	D-5	5
5305-00-021-3620	D-1	31	7310-00-999-2560	D-5	22
5305-00-054-6666	D-4	29	7310-00-999-2562	D-4	30
5305-00-054-6668	D-1	33	7310-00-999-5214	D-4	
5305-00-057-9610	D-4	4	7310-01-016-2241	D-4	32
5305-00-069-5122	D-4	22A	7310-01-016-2242	D-6	12
5305-00-082-6721	D-4	7 & 23	7310-01-017-1285	D-4	
5305-00-760-5520	D-4	24	7310-01-062-7074	D-4	32A
5305-00-984-6206	D-4	26	7310-01-280-0458	D-6	1
5305-00-984-6211	D-6	18	7310-01-449-9955	D-6	8
5310-00-275-6604	D-6	10	7320-00-680-2635	D-2	7
5310-00-543-2739	D-1	33A	7330-00-148-7173	D-2	23
5310-00-637-9541	D-4	34	7330-00-205-1950	D-2	18
5310-00-638-3899	D-4	33	7330-00-205-3151	D-3	14
5310-00-933-8121	D-1	31A	7330-00-238-8316	D-2	9
5310-00-999-2563	D-6	19	7330-00-238-8316	D-2	9
5315-00-842-3044	D-1	45	7330-00-248-1153	D-2	6
5320-00-010-4127	D-1	28	7330-00-250-6300	D-2	20
5320-00-068-2279	D-1	54	7330-00-263-8516	D-2	3
5320-00-069-1808	D-1	13	7330-00-272-2489	D-2	5
5320-00-129-9706	D-1	21	7330-00-272-2589	D-2	19
5320-00-754-0994	D-1	11	7330-00-272-7876	D-2	10
5320-00-754-0994	D-1	38	7330-00-292-2306	D-2	2
5320-00-772-3949	D-1	7	7330-00-292-2307	D-2	1
5320-00-772-3949	D-1	24	7330-00-379-2495	D-2	4
5320-00-772-3949	D-1	51	7330-00-485-7376	D-2	22
5320-00-837-3473	D-1	6	7330-00-550-7592	D-2	17
5320-00-909-7883	D-1	3	7330-00-634-1995	D-2	8
5320-01-237-2696	D-1	19	7330-00-680-0865	D-2	14
5330-01-362-3428	D-6	1B	7330-00-680-2635	D-2	7
5340-00-933-3596	D-4	8A	7330-00-815-1458	D-2	25
5340-00-999-9887	D-1	10	7340-00-197-1271	D-2	12
5340-01-109-7884	D-1	2	7340-00-223-7791	D-2	16
5345-00-198-8040	D-3	2	7340-00-223-7800	D-2	15
5355-00-999-2494	D-4	9	7340-00-255-0702	D-2	21
5360-00-926-5331	D-1	48	7340-00-488-7939	D-2	11
6685-00-999-2503	D-6	4	7340-00-488-7950	D-2	13
7240-00-177-6154	D-3	18	7360-00-106-5965	D-3 & D-2	1 & 27
7310-00-302-7941	D-4		7360-00-402-2403	D-3	9
7310-00-999-2474	D-4	12	7360-00-402-4495	D-3	10
7310-00-999-2478	D-4	37	7360-00-702-1719	D-1	
7310-00-999-2480	D-4	11	7360-00-999-3911	D-1	57
7310-00-999-2482	D-4	5	7360-00-999-9881	D-1	32
7310-00-999-2485	D-5	4	7360-00-999-9882	D-1	5
7310-00-999-2487	D-5	21	7360-00-999-9884	D-1	50
7310-00-999-2489	D-4 & D-5	15 & 15	7360-00-999-9885	D-1	47
7310-00-999-2490	D-4	25	7360-01-159-8294	D-1	23
7310-00-999-2491	D-4	27	7360-01-343-9014	D-7	1
7310-00-999-2492	D-4	28	7690-00-999-2509	D-6	15
7310-00-999-2493	D-4	31	7690-01-082-2865	D-6	14A
7310-00-999-2495	D-4	10	7920-00-291-5815	D-3	7
7310-00-999-2496	D-4	6	7920-00-514-2417	D-3	20
7310-00-999-2498	D-4	38	7930-00-003-8582	D-6	14
7310-00-999-2499	D-4	35	8030-00-087-8630	D-3	11
			9150-00-252-6173	D-3	12

Section IV. INDEX-REFERENCE NUMBER CROSS-REFERENCE TO FIGURE AND ITEM NUMBER

REFERENCE NO.	MFG CODE	FIG NO.	ITEM NO.	REFERENCE NO.	MFG CODE	FIG NO.	ITEM NO.
*MIL-R-24243/1B402	81349	D-1	23A	5-11-1236-6-3	81337	D-4	28
*MIL-R-2423/1-F402	81349	D-1	21	5-11-1236-6-5	81337	D-4	30
*MIL-T-83483	81349	D-3	11	5-11-1236-6-7	81337	D-4	29
*MS35206-264	96906	D-6	18	5-11-1236-6-8	81337	D-4	26
*MS35307-307	96906	D-1	31	5-11-1236-7	81337	D-4	9
*MS35333-72	96906	D-1	33A	5-11-1236-7-3	81337	D-4	8A
*MS35338-139	96906	D-1	31A	5-11-1237-8	81337	D-4	37
*MS51861-12C	96906	D-5	1	5-11-1238-9	81337	D-4	10
*MS51861	96906	D-4	4	5-11-1238-9-20	81337	D-4	19
*RR-C-271 TY II-CL3	81348	D4 & D-6	8 & 3	5-11-1238-9-21	81337	D-4	18
*VV-L-800	81348	D-3	12	5-11-1239-9-13	81337	D-4 & D-6	16
*GGG-W-657	81348	D-3	19	5-11-1239-9-16	81337	D-4	11
2-09-108	81337	D-3	16	5-11-1239-9-17	81337	D-4 & D-6	17
2-09-108	81337	D-8	1	5-11-1240-10	81337	D-4	32
2-09-120 SIZE 2	81349	D-2	1	5-11-1240-10-8	81337	D-4	33
2-09-35	81349	D-2	20	5-11-1240-30	81337	D-4	32A
2-09-35 SIZE 12	81349	D-2	2	5-11-1240-7	81337	D-4	34
5-11-1225-1	81337	D-4		5-11-1241-10-9	81337	D-4	35
5-11-1225-16	81337	D-4	24	5-11-1241-10-10	81337	D-4	38
5-11-1225-17	81337	D-4	36	5-11-1242-13	81337	D-6	4
5-11-1225-18	81337	D-4	7 & 23	5-11-1242-14	81337	D-6	11
5-11-1225-26	81337	D-4	1	5-11-1242-20	81337	D-6	14
5-11-1226-2	81337	D-4	6	5-11-1242-28	81337	D-6	14A
5-11-1227-21	81337	D-6	13	5-11-1243-12	81337	D-4	3
5-11-1227-22	81337	D-6	15	5-11-1243-15	81337	D-4	2
5-11-1227-29	81337	D-6	12	5-11-1244-23	81337	D-4	20
5-11-1227-29-10	81337	D-6	10	5-11-1244-23-3	81337	D-4	21
5-11-1227-3-11	81337	D-6	9	5-11-1244-23-4	81337	D-4	22
5-11-1228-11	81337	D-4	5	5-11-1244-23-5	81337	D-4	22A
5-11-1228-3-16	81337	D-6	19	5-11-2071	81337	D-7	1
5-11-1229-25	81337	D-6	8	5-11-2071-14	81337	D-6	5
5-11-1229-4-1-3	81337	D-6	1A	5-11-2072	81337	D-6	1B
5-11-1229-4-4	81337	D-6	2	5-11-2074	81337	D-1	23B
5-11-1229-4A	81337	D-6	1	5-11-2075-1	81337	D-3	4
5-11-1230-5	81337	D-5		5-11-353	81337	D-2	27
5-11-1231-5-1	81337	D-5	3	5-11-353-1	81337	D-2	30
5-11-1231-5-7	81337	D-5	2	5-11-353-2	81337	D-2	33
5-11-1232 PC5-10	81337	D-3	15	5-11-353-3	81337	D-2	31
5-11-1232-5-10	81337	D-5	5	5-11-353-4	81337	D-2	34
5-11-1232-5-45	81337	D-5	10	5-11-353-5	81337	D-2	29
5-11-1232-5-48	81337	D-5	4	5-11-353-6	81337	D-2	28
5-11-1233-5-19	81337	D-5	7	5-11-353-7	81337	D-2	24
5-11-1233-5-20	81337	D-5	6	5-11-353-7	81337	D-2	35
5-11-1233-5-27	81337	D-5	8	5-11-353-8	81337	D-2	32
5-11-1234-5-31	81337	D-5	22	5-11-414	81337	D-1	
5-11-1234-5-38	81337	D-5	9	5-11-414-20	81337	D-1	54
5-11-1235-5-32	81337	D-5	21	5-11-414-22	81337	D-1	56
5-11-1235-5-33	81337	D-5	16	5-11-414-29	81337	D-1	33
5-11-1235-5-34	81337	D-5	15	5-11-414-31	81337	D-1	24
5-11-1235-5-35	81337	D-5	17	5-11-414-31	81337	D-1	51
5-11-1235-36	81337	D-5	18	5-11-414-32	81337	D-1	1
5-11-1235-37	81337	D-5	11	5-11-414-39	81337	D-1	34
5-11-1235-40	81337	D-5	14	5-11-416-1-7	81337	D-1	67
5-11-1235-41	81337	D-5	13	5-11-416-1-11	81337	D-1	69
5-11-1235-41	81337	D-4	12	5-11-416-1-12	81337	D-1	69
5-11-1235-42	81337	D-5	20	5-11-416-1-13	81337	D-1	69
5-11-1235-43	81337	D-5	19	5-11-416-1-14	81337	D-1	69
5-11-1235-44	81337	D-5	12	5-11-416-1-15	81337	D-1	60
5-11-1235-6-4	81337	D-4	31	5-11-416-1-16	81337	D-1	61
5-11-1235-9-14	81337	D-4	15	5-11-416-1-17	81337	D-1	62
5-11-1235-9-15	81337	D-4	14	5-11-416-1-19	81337	D-1	63
5-11-1235-9-23	81337	D-4	13	5-11-416-1-20	81337	D-1	69
5-11-1236-6	81337	D-4		5-11-416-1-21	81337	D-1	68
5-11-1236-6-1	81337	D-4	25	5-11-416-1-22	81337	D-1	64
5-11-1236-6-2	81337	d-4	27				

*For reference only

Section IV. INDEX-REFERENCE NUMBER CROSS-REFERENCE TO FIGURE AND ITEM NUMBER

REFERENCE NO.	MFG CODE	FIG NO.	ITEM NO.	REFERENCE NO.	MFG CODE	FIG NO.	ITEM NO.
5-11-416-1-23	81337	D-1	65	5-11-424-17	81337	D-1	58
5-11-416-1-24	81337	D-1	66	5-11-424-36	81337	D-1	44
5-11-417-3	81337	D-1	32	5-11-425-13-1	81337	D-1	50
5-11-417-3-4	81337	D-1	38	5-11-425-13-2	81337	D-1	55
5-11-417-3-6	81337	D-1	39	5-11-425-13-4	81337	D-1	48
5-11-417-3-12	81337	D-1	42	5-11-425-13-5	81337	D-1	49
5-11-417-3-13	81337	D-1	35	5-11-425-13-8	81337	D-1	52
5-11-417-3-14	81337	D-1	36	5-11-425-14-2	81337	D-1	55
5-11-417-3-15	81337	D-1	37	5-11-71-34	81337	D-2	4
5-11-417-3-15	81337	D-1	43	5-11-907	81337	D-3	8
5-11-418-3-2	81337	D-1	41	5-11-910-25	81337	D-1	26
5-11-418-3-5	81337	D-1	40	5-11-910-8	81337	D-1	2
5-11-419-6	81337	D-1	5	5-11-910-9	81337	D-1	25
5-11-419-6-16	81337	D-1	11	5-11-964	81337	D-3	10
5-11-419-6-17	81337	D-1	13	5-11-964	81337	D-3	9
5-11-419-6-18	81337	D-1	7	A-A-1072	58536	D-2	7
5-11-419-6-20	81337	D-1	16	A-A-1082 TYPE II, SIZE 2	81349	D-2	21
5-11-419-6-23	81337	D-1	29	A-A-1640 TYPE I STYLE A	81349	D-2	8
5-11-419-6-26	81337	D-1	53	A-A-1752 TYPE II SIZE I	81348	D-2	5
5-11-419-6-27	81337	D-1	4	A-A-1953	81349	D-2	9
5-11-419-6-28	81337	D-1	3	A-A-1954	81349	D-2	10
5-11-419-6-29	81337	D-1	27	A-A-1956 SIZE 2	81348	D-2	14
5-11-419-6-32	81337	D-1	30	A-A-1956 SIZE 3	81348	D-2	6
5-11-419-6-38	81337	D-1	6	A-A-2344	81348	D-3	6
5-11-419-6-39	81337	D-1	28	A-A-2733 TYPE III	81348	D-2	12
5-11-419-6-40	81337	D-1	12A	A-A-2733 TYPE IV	81348	D-2	13
5-11-419-6-42	81337	D-1	19	A-A-2733 TYPE V	81348	D-2	11
5-11-420-6-7	81337	D-1	22	A-A-2733 TYPE X	81348	D-2	17
5-11-420-6-8	81337	D-1	23	A-A-2888	81348	D-3	5
5-11-420-11	81337	D-1	15	A-A-289 TYPE 2	81348	D-3	20
5-11-420-12	81337	D-1	17	A-A-3068/3	81348	D-3	2
5-11-420-13	81337	D-1	20	A-A-3118	81348	D-3	7
5-11-420-15	81337	D-1	14	A-A-394	81348	D-2	25
5-11-420-19	81337	D-1	10	A-A-52068	81349	D-2	18
5-11-420-21	81337	D-1	12	A-A-52201, ITEM 1	81349	D-2	22
5-11-420-22	81337	D-1	12	A-A-52201, ITEM 2	81349	D-2	3
5-11-420-24	81337	D-1	29	A-A-52201, ITEM 3	81349	D-2	23
5-11-420-25	81337	D-1	30	A-A-52204 TYPE I SIZE I	81349	D-2	16
5-11-420-36	81337	D-1	8	A-A-52204 TYPE II SIZE 2	81349	D-2	15
5-11-420-37	81337	D-1	9	A-A-52206	81348	D-3	14
5-11-421-6-2	81337	D-1	18	ANSI B107.15	96906	D-3	17
5-11-424-13-3	81337	D-1	47	ANSI B107.15	96906	D-3	3
5-11-424-14-3	81337	D-1	45	ANSI B107.6	96906	D-3	1
5-11-424-14-4	81337	D-1	46	BMC6256	18895	D-4	
5-11-424-15	81337	D-1	57	UL 154	81348	D-3	13
5-11-424-16	81337	D-1	59				

**SECTION IV. SUPPLEMENTARY INDEX
NATIONAL STOCK NUMBER TO FIGURE AND ITEM NUMBER**

STOCK NUMBER	FIGURE NO.	ITEM NO.
5120-00-234-8913	D3	17

**SECTION IV. SUPPLEMENTARY INDEX
REFERENCE NUMBER CROSS-REFERENCE TO FIGURE AND ITEM NUMBER**

REFERENCE NO.	MFG CODE	FIG. NO.	ITEM NO.
ANSI B107.15	96906	D3	17

APPENDIX E

ADDITIONAL AUTHORIZATION LIST

Section I. INTRODUCTION

E-1. SCOPE.

This appendix lists additional items authorized for the support of the field range outfit.

E-2. GENERAL.

This list identifies items that do not have to accompany the range outfit and that do not have to be turned in with it. These items are all authorized to you by CTA, MTOE, TAD, or JTA.

E-3. EXPLANATION OF LISTING.

National stock numbers, descriptions, and quantities are provided to help you identify and request the additional items you require to support this equipment. If item required differs for different models of this equipment, the model is shown under the "Usable on" heading in the description column. These codes are identified as:

Code	Used On
BEC	Model M59
BED	Model M2, M2A, and M2A with Safety Device
BZZ	Accessory Outfit with Baking Rack

Section II. ADDITIONAL AUTHORIZATION LIST

(1)	(2)		(3)	(4)
NATIONAL STOCK NUMBER	PART NUMBER	FSCM	USABLE ON CODE	QTY AUTH

There are no additional AAL Items authorized.

APPENDIX F

EXPENDABLE SUPPLIES AND MATERIALS LIST

Section I. INTRODUCTION

F-1. SCOPE.

This appendix lists expendable supplies and materials you will need to operate and maintain the range outfit. These items are authorized to you by CTA 50-970, Expendable Items (Except Medical, Class V, Repair Parts, and Heraldic Items).

F-2. EXPLANATION OF COLUMNS.

a. *Column 1- Item number.* This number is assigned to the entry in the listing and is referenced in the narrative instructions to identify the material (e.g., “Use cleaning compound, item, 5App. F”).

b. *Column 2- Level.* This column identifies the lowest level of maintenance that requires the listed item.

- C - Operator/Crew
- O - Organizational Maintenance
- F - Direct Support Maintenance

c. *Column 3- National Stock Number.* This is the National Stock Number assigned to the item; use it to request or requisition the item.

d. *Column 4- Description.* Indicates the Federal item name and, if required, a description to identify the item. The last line for each item indicates the part number followed by the Federal Supply Code for manufacturer (FSCM) in parentheses, if applicable.

If item requirement differs for different models of this equipment, the model is shown under the “Usable On” heading in the description column. These codes are identified:

CODE	USED ON
BEC	Model M59
BED	Model M2, M2A and M2A with Safety Device
BZZ	Accessory Outfit with Baking Rack

e. *Column 5 - Unit of Measure (U/M...* Indicates the measure used in performing the actual maintenance function. This measure is expressed by a two-character alphabetical abbreviation (e.g. ea, in, pr). If the unit of measure differs from the unit of issue, requisition the lowest unit of issue that will satisfy your requirements.

TABLE F-1. EXPENDABLE SUPPLIES AND MATERIALS LIST

(1) ITEM NUMBER	(2) LEVEL	(3) NATIONAL STOCK NUMBER	(4) DESCRIPTION	(5) USABLE ON CODE	(6) U/M
1	C	8030-00-251-5048	Compound Corrosion Prevent P14	BEC	GAL
2	C	9130-00-160-1818	Gasoline, Automotive, Combat	BED	BK
3	C	8135-00-226-3124	Barrier Material	BEC BED BZZ	ROLL
4	C	8030-00-087-8630	Anti Seize Compound	BEC BED	
5	O	6850-00-664-5685	Solvent,Dry Cleaning (P-D-680)*	BED	
6	O	9150-00-252-6173	Oil Preserving P-10	BED	
7	O	8010-00-664-7468	Paint, Heat Resisting, Aluminum (TT-P-28)*	BED	8 OZ
8	O	9920-00-889-3367	Matches (EE-M-101)*	BED	BOX
9	C	8415-01-092-3910	Gloves,Heat Protective (MIL-G-44013)*	BED	PAIR

* For reference only

INDEX

Subject	Paragraph	Page
A		
Air Shutter Assembly and Mixing Chamber.....	4-9.3	4-9
Air Valve Assembly.....	3-4.2	3-6
Air Valve Assembly.....	4-9.7	4-17
Assembly and Preparation For Use.....	2-5	2-11
Assembly, Fuel Tank.....	4-9.6	4-15
Assembly, Lid.....	4-8.1	4-5
Assembly, Preheater.....	4-9.4	4-12
B		
Baking Rack Set.....	2-5.5	2-18
Bottom Shield.....	4-9.3	4-9
Burner, Fuel Feeder Tube, Bottom Shield and Mixing Chamber and Air Shutter Assembly.....	4-9.3	4-9
Burner Unit.....	4-9,4-10.1	4-7,4-18
C		
Cabinet.....	4-8,4-10.2, 5-2	4-5,4-19,5-1
Cabinet Hardware.....	5-2.3	5-1
Chamber, Mixing.....	4-9.3	4-9
Cleaning.....	2-3	2-11
Common Tools and Equipment.....	4-2	4-1
Cradle.....	4-8.3	4-6
D		
Data, Equipment.....	1-7	1-3
Description and Use of Operator's Control and Indicators.....	2-1	2-1
Differences Between Models.....	1-6	1-3
Dismantling for Movement.....	2-8	2-24
Door Hardware.....	5-2.2	5-1
E		
Equipment Data.....	1-7	1-3
Equipment Purpose Capabilities and Features.....	1-4	1-1
Equipment, Reporting Improvement and Recommendations.....	1-3	1-1
Equipment, Special Tool and Support.....	4-3	4-1
Extinguisher, Fire.....		C-5
F		
Filler Cap Assembly.....	4-9.8	4-17
Fire Extinguisher.....		C-5
Forms and Records, Maintenance of.....	1-2	1-1
Frame.....	4-9.9	4-18

INDEX - Continued

Subject	Paragraph	Page
F		
Fuel Feeder Tube	4-9.3	4-9
Air Pressure Gage.....	4-9.5	4-14
Fuel Tank	4-9.6	4-15
G		
Gage, Air Pressure	4-9.5	4-14
Generator	3-4.1,4-9.2	4-3,4-8
H		
Handles, Lifting and Latches.	4-8.2	4-6
How It Works	1-8	1-7
I		
Inspecting the Equipment	2-5.3	2-11
Installation and Servicing the Equipment	2-5.4	2-11
L		
Lid Assembly	4-8.1	4-5
Lid Hardware	5-2.1	5-1
Lifting, Handles and Latches.	4-8.2	4-6
Location and Description of Major Components	1-5	1-3
Lubrication	3-2	3-1
M		
Maintenance Forms and Records	1-2	1-1
Mixing Chamber and Air Shutter Assembly	4-9.3	4-9
Movement, Dismantling For	2-8	2-24
Movement, Reinstallation After	2-9	2-25
O		
Operator's Controls and Indicators	2-1	2-1
Operation:		
At High Altitudes	2-16	2-26
In Dusty or Sandy Areas.....	2-13	2-25
In Extreme Cold	2-11	2-25
In Extreme Heat	2-12	2-25
In Saltwater Areas	2-15	2-26
Under Rainy or Humid Conditions.....	2-14	2-25
Operating the Field Range.....	2-10	2-25
P		
Preheater Assembly	4-9.4	4-12
Preventive Maintenance Checks and Services	2-2,4-6	2-1,4-1

INDEX - Continued

Subject	Paragraph	Page
R		
Reinstallation After Movement	2-9	2-25
Repair Parts	4-4	4-1
Reporting Equipment Improvement and Recommendations	1-3	1-1
S		
Scope	1-1,4-1	1-1,4-1
Servicing Equipment and Installation	2-5.4	2--11
Set, Baking Rack	2-5.5	2-18
Shield, Bottom	4-9.3	4-9
Shield, Top	4-9.1	4-7
Special Tools and Support Equipment	4-3	4-1
Starting the Equipment	2-6	2-18
Stopping the Equipment	2-7	2-24
Storage after Preparation for Storage	4-11	4-19
Safety Valve Device	4-9.10	4-18
Safety Valve Device Kit Instruction	4-9.11	4-18
T		
Tank, Fuel	4-9.6	4-15
Tools, Common and Equipment	4-2	4-1
Tools, Special and Support Equipment	4-3	4-1
Top Shield	4-9.1	4-7
Troubleshooting	3-3,4-7.1	3-1,4-3
U		
Unloading the Equipment	2-5.1	2-11
Unpacking the Equipment	2-5.2	2-11
Utensils	4-10.3	4-19

By Order of the Secretary of the Army:

Official:

ROBERT M. JOYCE
Major General, United States Army
The Adjutant General

JOHN A. WICKHAM, JR.
General, United States Army
Chief of Staff

These are the instructions for sending an electronic 2028

The following format must be used if submitting an electronic 2028. The subject line must be exactly the same and all fields must be included; however only the following fields are mandatory: 1, 3, 4, 5, 6, 7, 8, 9, 10, 13, 15, 16, 17, and 27.

From: "Whomever" <whomever@avma27.army.mil>

To: amssb-rim-e@natick-emh2.army.mil

Subject: DA Form 2028

1. **From:** Joe Smith
2. **Unit:** home
3. **Address:** 4300 Park
4. **City:** Hometown
5. **St:** MO
6. **Zip:** 77777
7. **Date Sent:** 19--OCT--93
8. **Pub no:** 55--2840--229--23
9. **Pub Title:** TM
10. **Publication Date:** 04--JUL--85
11. **Change Number:** 7
12. **Submitter Rank:** MSG
13. **Submitter FName:** Joe
14. **Submitter MName:** T
15. **Submitter LName:** Smith
16. **Submitter Phone:** 123--123--1234
17. **Problem:** 1
18. **Page:** 2
19. **Paragraph:** 3
20. **Line:** 4
21. **NSN:** 5
22. **Reference:** 6
23. **Figure:** 7
24. **Table:** 8
25. **Item:** 9
26. **Total:** 123
27. **Text:**

This is the text for the problem below line 27.



THEN ...JOT DOWN THE DOPE ABOUT IT ON THIS FORM, CAREFULLY TEAR IT OUT, FOLD IT AND DROP IT IN THE MAIL!

SOMETHING WRONG WITH THIS PUBLICATION?

FROM: (PRINT YOUR UNIT'S COMPLETE ADDRESS)

*PFC John DOE
CO A 3rd Engineer Bn
Ft. Leonardwood, MO 63108*

DATE SENT

22 August 1992

PUBLICATION NUMBER

TM 1-1520-250-10

PUBLICATION DATE

15 June 1992

PUBLICATION TITLE

Operator's manual MH60K Helicopter

BE EXACT PIN-POINT WHERE IT IS

IN THIS SPACE, TELL WHAT IS WRONG AND WHAT SHOULD BE DONE ABOUT IT:

PAGE NO	PARA-GRAPH	FIGURE NO	TABLE NO
6	2-1 a		
B1		4-3	

In line 6 of paragraph 2-1a the manual states the engine has 6 cylinders. The engine on my set only has 4 cylinders. Change the manual to show 4 cylinders.

Callout 16 on figure 4-3 is pointed at a bolt. In key to figure 4-3, item 16 is called a shim. Please correct one or the other

PRINTED NAME, GRADE OR TITLE, AND TELEPHONE NUMBER

JOHN DOE, PFC (268) 317-7111

SIGN HERE

JOHN DOE John Doe

RECOMMENDED CHANGES TO EQUIPMENT TECHNICAL PUBLICATIONS



THEN . . . JOT DOWN THE DOPE ABOUT IT ON THIS FORM, CAREFULLY TEAR IT OUT, FOLD IT AND DROP IT IN THE MAIL!

SOMETHING WRONG WITH THIS PUBLICATION?

FROM: (PRINT YOUR UNIT'S COMPLETE ADDRESS)

DATE SENT

PUBLICATION NUMBER TM 10-7360-204-13&P	PUBLICATION DATE 8 July 1983	PUBLICATION TITLE RANGE, OUTFIT, FIELD, GASOLINE
--	--	--

BE EXACT PIN-POINT WHERE IT IS IN THIS SPACE, TELL WHAT IS WRONG AND WHAT SHOULD BE DONE ABOUT IT:

PAGE NO	PARA-GRAPH	FIGURE NO	TABLE NO	

PRINTED NAME, GRADE OR TITLE, AND TELEPHONE NUMBER	SIGN HERE
---	------------------

FILL IN YOUR
UNITS ADDRESS



FOLD BACK

DEPARTMENT OF THE ARMY

OFFICIAL BUSINESS

COMMANDER
U.S. ARMY SOLDIER SYSTEMS COMMAND
ATTN: AMSSB-RIM-E
KANSAS STREET
NATICK, MA 91760-5000

TEAR ALONG PERFORATED LINE

The Metric System and Equivalents

Linear Measure

1 centimeter = 10 millimeters = .39 inch
 1 decimeter = 10 centimeters = 3.94 inches
 1 meter = 10 decimeters = 39.37 inches
 1 dekameter = 10 meters = 32.8 feet
 1 hectometer = 10 dekameters = 328.08 feet
 1 kilometer = 10 hectometers = 3,280.8 feet

Weights

1 centigram = 10 milligrams = .15 grain
 1 decigram = 10 centigrams = 1.54 grains
 1 gram = 10 decigrams = .035 ounce
 1 dekagram = 10 grams = .35 ounce
 1 hectogram = 10 dekagrams = 3.52 ounces
 1 kilogram = 10 hectograms = 2.2 pounds
 1 quintal = 100 kilograms = 220.46 pounds
 1 metric ton = 10 quintals = 1.1 short tons

Liquid Measure

1 centiliter = 10 milliliters = .34 fl. ounce
 1 deciliter = 10 centiliters = 3.38 fl. ounces
 1 liter = 10 deciliters = 33.81 fl. ounces
 1 dekaliter = 10 liters = 2.64 gallons
 1 hectoliter = 10 dekaliters = 26.42 gallons
 1 kiloliter = 10 hectoliters = 264.18 gallons

Square Measure

1 sq. centimeter = 100 sq. millimeters = .155 sq. inch
 1 sq. decimeter = 100 sq. centimeters = 15.5 sq. inches
 1 sq. meter (centare) = 100 sq. decimeters = 10.76 sq. feet
 1 sq. dekameter (are) = 100 sq. meters = 1,076.4 sq. feet
 1 sq. hectometer (hectare) = 100 sq. dekameters = 2.47 acres
 1 sq. kilometer = 100 sq. hectometers = .386 sq. mile

Cubic Measure

1 cu. centimeter = 1000 cu. millimeters = .06 cu. inch
 1 cu. decimeter = 1000 cu. centimeters = 61.02 cu. inches
 1 cu. meter = 1000 cu. decimeters = 35.31 cu. feet

Approximate Conversion Factors

To change	To	Multiply by	To change	To	Multiply by
inches	centimeters	2.540	ounce-inches	newton-meters	.007062
feet	meters	.305	centimeters	inches	.394
yards	meters	.914	meters	feet	3.280
miles	kilometers	1.609	meters	yards	1.094
square inches	square centimeters	6.451	kilometers	miles	.621
square feet	square meters	.093	square centimeters	square inches	.155
square yards	square meters	.836	square meters	square feet	10.764
square miles	square kilometers	2.590	square meters	square yards	1.196
acres	square hectometers	.405	square kilometers	square miles	.386
cubic feet	cubic meters	.028	square hectometers	acres	2.471
cubic yards	cubic meters	.765	cubic meters	cubic feet	35.315
fluid ounces	milliliters	29.573	cubic meters	cubic yards	1.308
pints	liters	.473	milliliters	fluid ounces	.034
quarts	liters	.946	liters	pints	2.113
gallons	liters	3.785	liters	quarts	1.057
ounces	grams	28.349	liters	gallons	.264
pounds	kilograms	.454	grams	ounces	.035
short tons	metric tons	.907	kilograms	pounds	2.205
pound-feet	newton-meters	1.356	metric tons	short tons	1.102
pound-inches	newton-meters	.11296			

Temperature (Exact)

°F Fahrenheit temperature 5/9 (after subtracting 32) Celsius temperature °C

PIN: 049638-011